

VERTICALE[®] CERVICAL NAVIGATION

SURGICAL TECHNIQUE & PRODUCT GUIDE

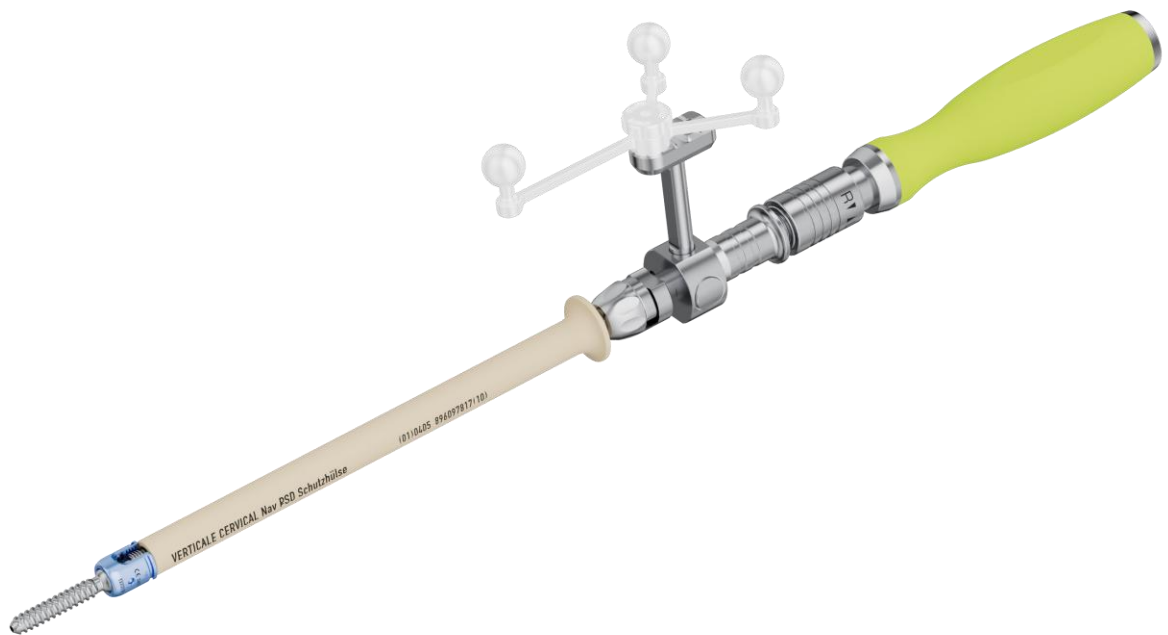

MADE IN
GERMANY

TABLE OF CONTENTS

Preface..... 3

Navigation Instruments..... 4

Surgical Technique..... 12

Product Guide..... 17

NOTE: The following guide is intended to familiarize you with the surgical procedure and use of the VERTICALE CERVICAL Navigable Instruments. This instrumentation guide supplements the guides for the VERTICALE CERVICAL Screw Rod System. Instruments from Silony Spine are processed, serviced, and cared for in accordance with the information given in the instructions for use (D30223). Please read this guide and the instructions for use accompanying the implants carefully before using the implants. This guide does not replace briefing by a surgeon experienced in the instrumentation used in spinal surgery.

NOTE: Silony Spine does not manufacture or provide navigation systems or equipment. Please refer to the navigation company’s software and user guides for instructions for use and training prerequisites on the navigation system. Instructions for use and handling of any third-party navigation systems in combination with Silony instruments are the responsibility of the hospital and navigation company. The navigation system should be set up per the manufacturer’s instructions.

PREFACE

NAVIGABLE INSTRUMENTS FOR VERTICALE[®] CERVICAL SCREW ROD SYSTEM FROM SILONY SPINE

The VERTICALE CERVICAL navigable instruments are compatible with:

- the Medtronic StealthStation[®] navigation system and the SureTrak[®]II Universal tracker
- Brainlab navigation system and the Brainlab universal instrument adapter clamps (StarLink[®])
- 7D navigation system and the 7D Surgical Universal clamps

For general instructions on use, indications, contraindications and warnings please refer to the following Instructions for Use and instrumentation guides:

- VERTICALE CERVICAL technique and product guide
- Instructions for Use for VERTICALE CERVICAL implants
- Instructions for Use for Silony surgical instruments
- Medtronic's current navigation system software and user guides (StealthStation[®])
- Brainlab's current navigation system software and user guides (StarLink[™])
- 7D Surgical's current navigation system software and user guides (Flash[™])

Before using the VERTICALE CERVICAL navigable instruments for the VERTICALE CERVICAL Screw Rod System, the physician and user should familiarize themselves with the application area in the Instructions for Use of the Silony Spine VERTICALE CERVICAL system as well as the third-party navigation system.

The VERTICALE CERVICAL navigable instruments are exclusively intended for use with VERTICALE CERVICAL implants from Silony Spine and are NOT compatible with implants from other manufacturers.

VERTICALE[®] CERVICAL NAVIGATION INSTRUMENTS

Please refer to the supplemental VERTICALE[®] CERVICAL Instrument Guides and Instructions for use for general procedural instructions, indications, contraindications and warnings.

Please consider the following additional information for Navigation use:

The VERTICALE[®] CERVICAL Navigation Instruments are indicated for use during the preparation and insertion of VERTICALE[®] Cervical screws during spinal surgery to assist the surgeon in precisely locating anatomical structures in either open or minimally invasive procedures. These instruments are designed for use with the third party stereotactic navigation systems (Medtronic StealthStation[™], Brainlab or 7D) software, which are indicated for any medical condition in which the use of stereotactic surgery is suitable, and where reference to a rigid anatomical structure, such as vertebra, can be identified relative to a CT or MR based model, fluoroscopy images, or digitized orientation points of the anatomy.

Medical conditions which contraindicate the use of a computer-assisted surgery system and its associated applications with Silony Spine VERTICALE CERVICAL system include any medical conditions which may contraindicate the medical procedure itself.

NOTE: Instructions for use are provided with each product. They may include additional advice that leads to exclusion of the implant procedure. All surgical technique guides and Instructions for use can be found on our eLabeling portal (<https://elabeling.silony-medical.com/>)

NAVIGATION SYSTEM PREPARATION AND INSTRUMENTATION

Prerequisites for Navigation System, the universal adapter clamps and associated arrays

Warning: Instruments should only be used with the software version that has been validated.

Warning: The surgeon should be trained on the navigation system prior to performing procedure.

The Silony VERTICALE CERVICAL navigable instruments are used in conjunction with the universal adapter clamps and associated arrays of the respective navigation system. They therefore require manual registration and calibration before they can be used (see the section on instrument registration). This means that the dimensions of the Silony Spine VERTICALE CERVICAL navigable instruments must be correctly measured and verified through the calibration process in the respective navigation system. Please refer to the instructions for the clamps and universal trackers for the manual calibration of the respective third-party.

NOTE: To use Silony instruments in a navigated manner, the hospital must have the following components in the appropriate size and quantity:

Navigation System	Respective instrument tracker / array
Medtronic StealthStation® System S8*	SureTrak®II Universal Tracker
Brainlab**	Clamps and arrays of the Universal Instrument Adapters (Star- Link™)
7D Surgical***	7D Universal Tracking Clamps

Silony Spine navigation instruments require following the instructions for use for the respective third-party navigation system and the associated navigation instruments, which are provided by the navigation system manufacturer. If the respective third-party navigation instrument set is not available at the hospital, the VERTICALE CERVICAL navigable Instruments cannot be used navigated. In the event that the respective third-party navigation instrument set is unavailable, a non-navigated technique using an image intensifier for verification and respective Silony Spine instrumentation may be adopted as per Silony Spine instrumentation guides.

*Note: Position verification was performed with Medtronic StealthStation System S8 and Software Version 1.30-49.

**Note: Position verification was performed with Brainlab Curve Software Version 1.5.1.444.

*** Note: Position verification was performed with 7D Surgical Software – Spine Module 2.4.1.0.

Assembly of the navigation adapter

The navigation adapters offer two different options for connecting with the third-party universal clamps.

- A clamping variant in which the third-party universal clamp is mounted on the specially designed geometry of the adapter.
- A screw variant in which the third-party navigation array is directly mounted on the specially designed interface of the adapter.

Use of third-party navigation universal adapter clamps and arrays

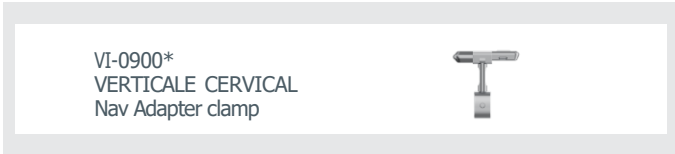

- 1) Assemble the third-party universal instrument adapter clamps and arrays according to the respective navigation manufacturer's instructions.
- 2) To use the universal clamps, connect the pre-assembled third-party universal instrument adapter clamps to the designated interface of the navigation adapter according to the respective navigation manufacturer's instructions. Always make sure that the clamp-array-assembly is fully seated on the interface of the navigation adapter and the array is oriented in line with the navigation adapter's axis such that the array pointing toward the working end of the instrument when assembled in the next step.

The VERTICALE CERVICAL Navigation Adapter with connected third-party universal clamps are further denoted by 'navigation tracker' (short 'tracker').

The following third-party clamp sizes can be mounted on the adapter:

Third-party:	Brainlab	Medtronic	7D
Clamp size:	Medium, Large	Small	Small

* Further adapters are shown in the chapter "Instruments"

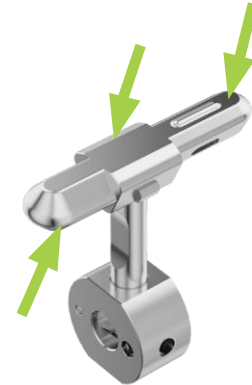

Fig. 1 VERTICALE CERVICAL Nav Adapter with interfaces for universal clamps



Fig. 2 VERTICALE CERVICAL Nav Adapter with universal clamps

Direct use of third-party navigation arrays

VI-0905
VERTICALE CERVICAL
Nav Adapter Screw 1



VI-0906
VERTICALE CERVICAL
Nav Adapter Screw 2



1. Mount the third-party navigation array with the designated screw directly onto the designated area of the navigation adapter, instead of mounting it on the universal clamp (as described in the previous section). Note that the VI-0905 is only compatible with the third-party navigation arrays from Medtronic and Brainlab, and the VI-0906 is only compatible with the 7D navigation array.
2. Check the connection between the adapter and the navigation array mounted and retighten the screws if necessary. Always make sure that the adapter-array-assembly is fully seated on the interface of the navigation adapter, and the array is oriented in line with the navigation adapter's axis such that the array is pointing toward the working end of the instrument when assembled in the next step.



Fig. 3 VI-0905 VERTICALE CERVICAL Nav Adapter Screw 1 for Brainlab and Medtronic, as well as VI-0906 VERTICALE CERVICAL Nav Adapter Screw 2 for 7D.

NOTE: Do not use the same array size on two different instruments without new registration procedure. For registration instructions, please refer to the registration section.

Assembly of navigable probe and awl

VI-0910
VERTICALE CERVICAL
Nav Awl



VI-0920
VERTICALE CERVICAL
Nav Probe



- 1) Slide the navigation adapter from the front onto the awl or probe until it clicks into place.
Ensure that the navigation adapter is securely connected to the respective instrument. Once a secure connection is established, the adapter is positioned axially fixed on the instrument, allowing free rotation of the tracker around the instrument's working axis.
- 2) To release the navigation adapter from the instrument, press the button to release the lock and pull the adapter forward off the instrument.

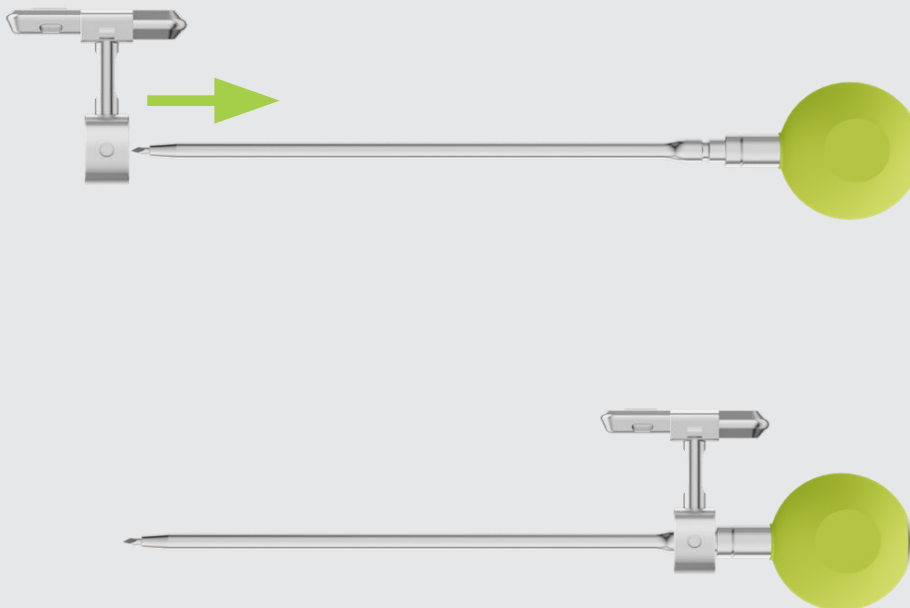

Fig. 4 Assembly of awl and navigation adapter

Assembly of navigable drill guide

VI-0940.1*
VERTICALE CERVICAL
Nav DG Basic Core



VI-0940.2**
VERTICALE CERVICAL
Nav DG TA fix



- 1) Insert one of the depth stops into the drill guide.
- 2) Slide the navigation adapter from the back onto the depth stop of the drill guide until it clicks into place. Ensure that the navigation adapter is securely connected to the respective instrument.

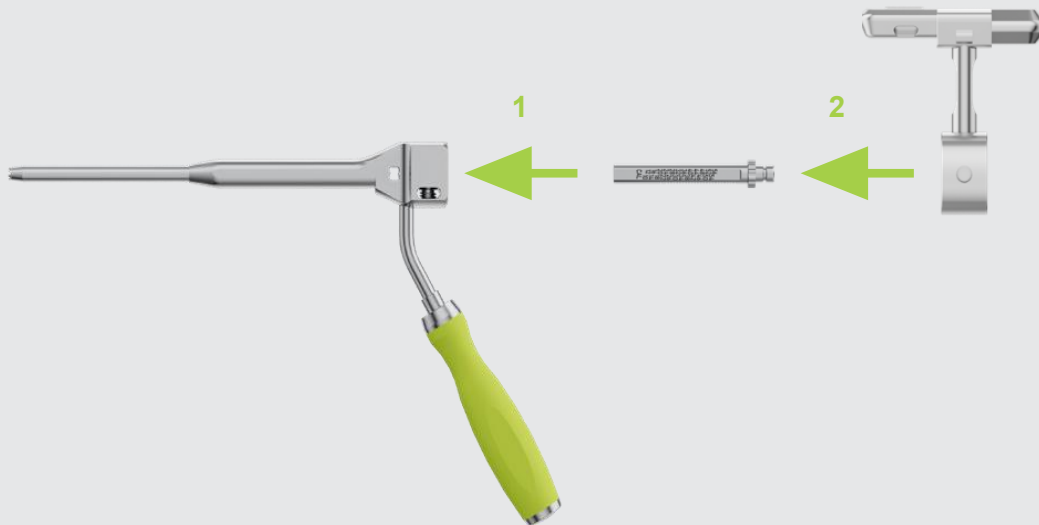

Fig. 5 Assembly of NAV drill guide and navigation adapter

*Additional navigated instruments can be found in the section "Instruments"

**Further depth stops are shown in the chapter "Instruments".

To release the navigation adapter from the instrument, press the button to release the lock and move the adapter backward.

Assembly of navigable pedicle screwdriver

VI-0930.1
VERTICALE CERVICAL
Nav PSD Basic Core



VI-0930.2
VERTICALE CERVICAL
Nav PSD Protection Sleeve



VI-0930.3
VERTICALE CERVICAL
Nav PSD Inner Shaft



- 1) Insert the inner shaft of the screwdriver from the front into the basic core.
- 2) If necessary, use the VERTICALE CERVICAL Tissue Protection Sleeve for the navigable screwdriver by sliding it onto the basic core from the front until it clicks into the designated recess.
- 3) Slide the navigation adapter from the back onto the basic core of the VERTICALE CERVICAL Screwdriver until it clicks into place. Ensure that the navigation adapter is securely connected to the respective instrument.
- 4) Use one of the modular handles to connect to the AO coupling of the instrument.

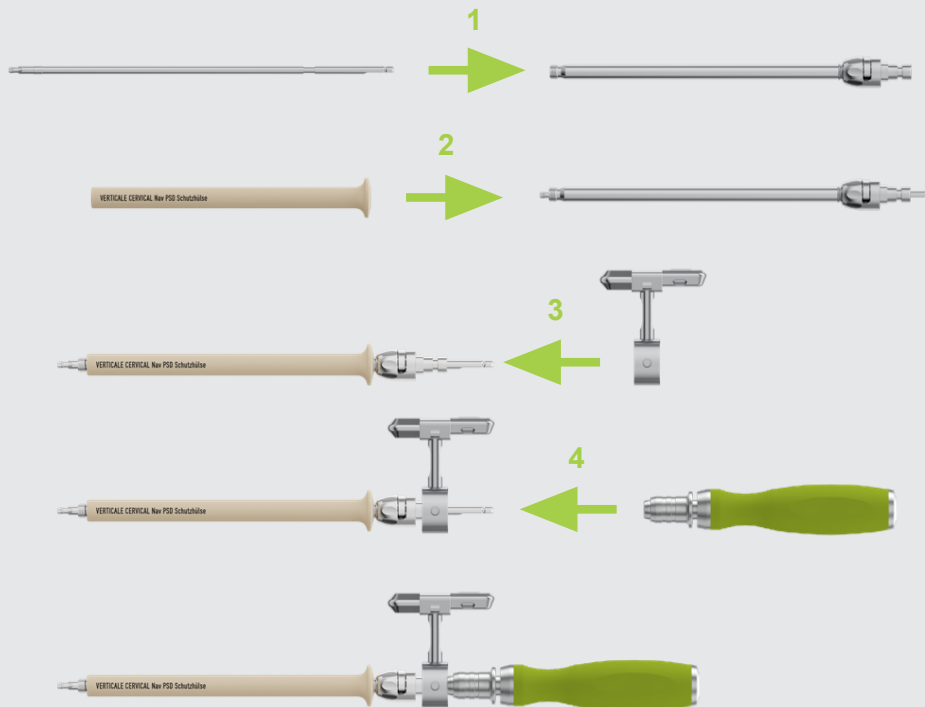

Fig. 6 Assembly of screwdriver and navigation adapter

To release the navigation adapter from the instrument, remove the modular handle and press the button to release the lock and move the adapter backward off the instrument.

Instrument registration instructions

Refer to the navigation manufacturer's current navigation software and user guides for patient referencing and instrument registration.

Medtronic: Follow the instructions for StealthStation® and SureTrak®II Universal Tracker.

Brainlab: Follow the instructions for manual calibration of third-party instruments with the clamps and arrays of the universal instrument adapter (StarLink™) and ICM4.

7D: Follow the instructions for manual calibration of instruments with the 7D Universal Tracking Clamps.

If you use VERTICALE CERVICAL navigable instruments with the VERTICALE CERVICAL navigation adapters, manual registration and calibration are required. This means the respective Silony navigable instrument dimensions need to be acquired through a manual calibration process. VERTICALE CERVICAL navigation instruments can be used for manual calibration by using the respective navigation system manufacturer's clamps and arrays for general instrument calibration and following their Instructions for Use.

For each instrument to be navigated with navigation systems based on a manual calibration process, the appropriate generic instrument card must be assigned and manual calibration performed according to the navigation manufacturer's instructions. For calibrating the drill guide, the VI-0941 calibration aid should be used, which corresponds in length to the drills and taps, thereby providing an accurate representation. The screwdriver always be manually calibrated with each attached screw.

Upon successful manual calibration, the trajectory and position of the distal tip of the instrument or screw are visually represented within the software by the generic instrument or genetic screw selected from the corresponding instrument cards. If you desire to change the tip of the virtual representation to reflect the diameter and length of the screw, follow the instructions of the chosen navigation system.

NOTE: Recalibration must be performed after any change to the calibrated instrumentation combination, e.g., change to the calibrated screw length.

SURGICAL TECHNIQUE GUIDE

Instrumentation / Surgical Steps

The following section describes the specific steps for the use of VERTICALE CERVICAL navigable instruments. For the general instrumentation steps of the CERVICAL system for an open approach, we ask you to study the instrumentation guide for the VERTICALE CERVICAL screw rod system.

Please review the following notes prior to using VERTICALE CERVICAL navigable instruments.

- Prior to navigation, always ensure that accuracy of the instrument tip or tip of screwdriver with rigidly connected screw is in an acceptable range for the intended use. Position the navigated tip on an identifiable anatomical landmark and compare the actual tip location to that displayed in the software.
- Assess navigational accuracy repeatedly throughout a procedure.
- After each change to the navigated instrumentation assembly in use (e.g., for each new screw; after re-attachment of tracker, adapter, clamp, array and spherical markers) when using a surgical navigation system, the calibrated navigated instrumentation assembly must be re-verified, and if necessary, recalibrated for accuracy.
- Discontinue use if inaccuracy is suspected.
- If the stereotactic navigation system does not appear to be accurate or registration of Silony instruments fails despite troubleshooting (e.g., resetting the system), do not rely on the navigation system. A non-navigated technique using an image intensifier and the respective Silony Spine instrumentation should be used as per Silony Spine Instrumentation guides.
- If the desired virtual screw or instrument diameter is not available in the software, use the next larger available size in diameter (e.g., Ø 3.5 mm Silony Spine screws - Software: select Ø 4.0 mm screw projection).
- Ensure the array on the tracker is visible to the camera of the respective navigation system used.
- For all navigable instruments, the navigation tracker will rotate around the instrument shaft.

Please hold the tracker with the hand for permanent camera visibility of the array markers while using the instrument.

- When inserting taps and screws, rotate proximal instrument handle clockwise. For removal rotate anticlockwise.
- Care should be taken to avoid bending forces on registered instruments during navigation procedure as elastic deflection can influence navigation accuracy.
- If the instrument appears to be damaged or its functionality could otherwise be impaired, re-verify it with respect to anatomical landmarks or use another instrument. Do not use any instrument if verification of anatomical landmarks fails. Omission to do so may lead to serious injury to the patient.
- Do not use the tracker and/or Silony instruments if any components appear to be loose, bent or otherwise damaged.
- Cannulated instruments (taps, screwdriver) are available for using guide wires.
- The guide wires are not navigable instruments.
- Ensure that the length of the guide wire exceeds the length of implant, instrument and additional handle.
- Slide the instrument over the placed guide wire.
- Ensure the guide wire remains securely in position throughout the entire duration of the procedure.
- Remove the guide wire after screw insertion and confirm the final screw position.

Position and approach

Please refer to the VERTICALE CERVICAL instrumentation guide for information on patient position and approach.

Opening of the cortex

VI-0910
VERTICALE CERVICAL
Nav Awl



VI-0920
VERTICALE CERVICAL
Nav Probe



Assemble and register the required instrument as described in the corresponding assembly and registration section.

Prior to navigation, please refer to general notes section. Please refer to the VERTICALE CERVICAL Instrumentation Guide for information on opening and preparing the pedicle with an awl or probe.

Drilling and tapping

VI-0940.1
VERTICALE CERVICAL
Nav STD Basic Core



VI-0940.2*
VERTICALE CERVICAL Depth
Stop fix



VI-0292*
VERTICALE CERVICAL
Drill 2.4 mm NAV DG



VI-0294*
VERTICALE CERVICAL
Tap 3.5 mm NAV DG



*Additional instruments can be found in the chapter "Instruments"

- 1) Assemble and register the drill guide as described in the corresponding assembly and registration section.
- 2) Assemble VI-0941 VERTICALE CERVICAL Calibration Insert with the drill guide to register the drill/drill guide assembly. The depth stop should be in the "CAL" position.
- 3) To set the maximum depth, press the button on the top of the drill guide. This allows the depth stop to be adjusted. Make sure the depth stop clicks into place at the desired position.
- 4) Slide the drill or thread cutter fully into the drill guide. Ensure that the movable part of the depth-stop clicks correctly into the recess of the drill or tap with the attached universal clamp.

Please refer to the VERTICALE CERVICAL Instrumentation Guide for information on drilling and tapping the pedicle with a drill and tap. Drill length equates to screw length from the tip of the screw to the tulip. Drill and screw penetrations shown.

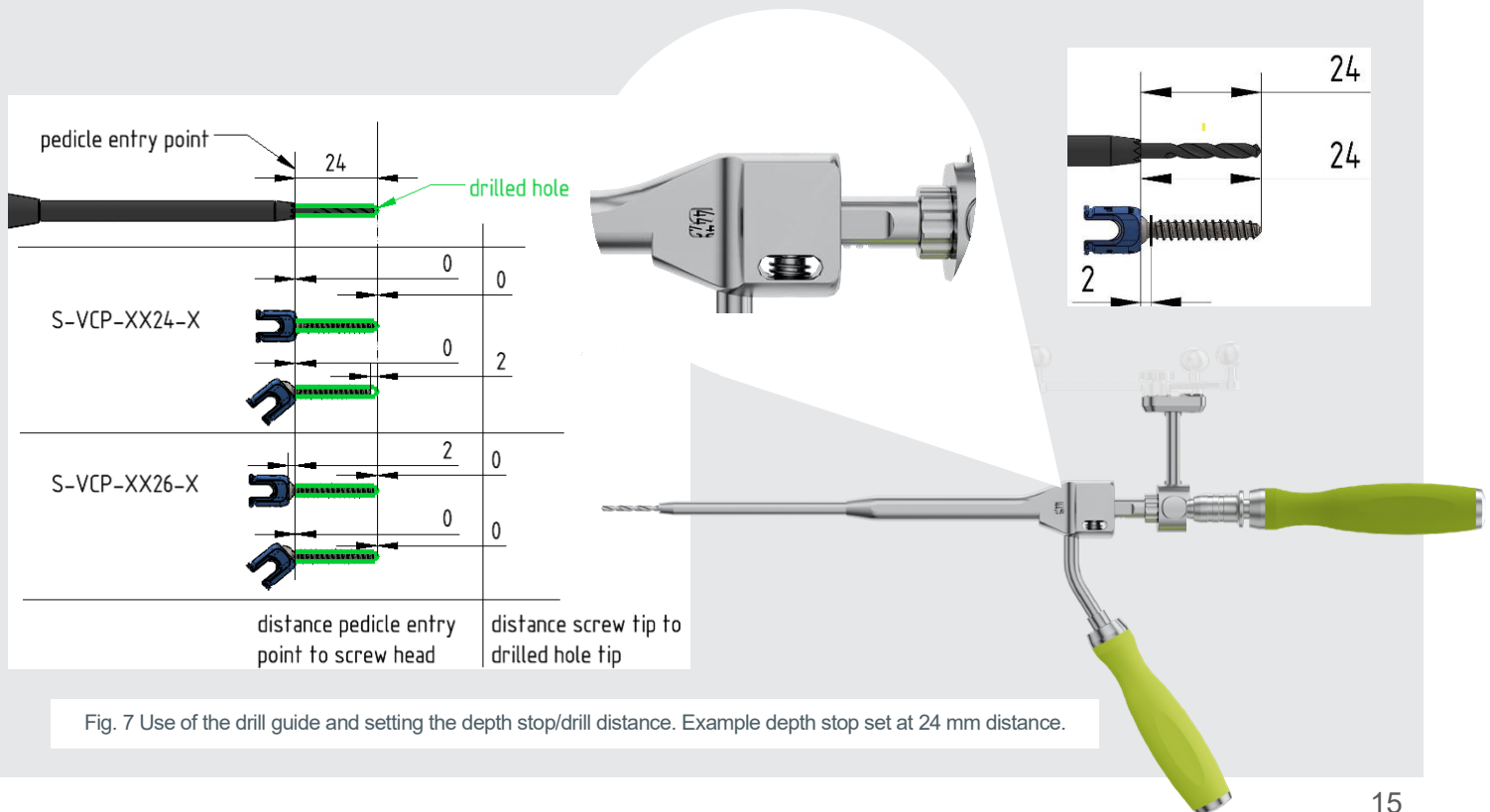

Fig. 7 Use of the drill guide and setting the depth stop/drill distance. Example depth stop set at 24 mm distance.

Screw loading with navigable screwdriver

VI-0930.1
VERTICALE CERVICAL
Nav PSD Basic Core



VI-0930.2
VERTICALE CERVICAL
Nav PSD Protection Sleeve



VI-0930.3
VERTICALE CERVICAL PSD Inner Shaft



Fig. 8 Screw loading with screw driver

Select the VERTICALE pedicle screw type and size (length and diameter) based on pre-operative planning and fluoroscopic imaging.

- 1) Assemble and register the navigable screwdriver as described in the corresponding assembly and registration section.
- 2) Load the screw, analogous to VI-0130.

The inner shaft of the VERTICALE CERVICAL pedicle screwdriver is first inserted deeply into the inner Torx socket of the screw.

After that, the threaded basic core is pushed towards the tulip, and the internal thread of the tulip is connected to the external thread of the instrument by rotating to knob of the screwdriver clockwise and applying mild downward force with the instrument shaft.

NOTE: Ensure the screwdriver tip is fully seated in the inner Torx and the connection is stable after tightening. Ensure that the T-shaped tip is sufficiently inserted into the tulip for secure locking of the screw to the pedicle screwdriver.

Pedicle screw insertion

NOTE: The tip position of the navigated instrument with loaded screw must be verified for accuracy prior to use when using a navigation system. Prior to navigation, please refer to general notes section. Please refer to the VERTICALE CERVICAL Instrumentation Guide for information on inserting the pedicle screw and disengaging the screwdriver.

NOTE: Do not hold the middle handle of the screwdriver basic core before releasing the screwdriver from the screw.

Please refer to the VERTICALE CERVICAL Instrumentation Guide for information on further surgical steps after screw placement or the implant removal procedure to complete surgery.



For insertion of additional screws, follow the previous steps for the remaining screws.





NOTE: If the screw is changed, the tip position of the navigated instrument with loaded new screw must be re-verified for accuracy prior to use. Prior to navigation, please refer to general notes section.

PRODUCT GUIDE

VERTICALE CERVICAL Navigation Instruments

This section gives an overview on compatible instruments of the VERTICALE CERVICAL Screw Rod System.

Article Number	Description	Figure
VI-0292	VERTICALE CERVICAL Drill 2.4 mm NAV DG	
VI-0293	VERTICALE CERVICAL Drill 2.9 mm NAV DG	
VI-0294	VERTICALE CERVICAL Tap 3.5 mm NAV DG	
VI-0295	VERTICALE CERVICAL Tap 4.0 mm NAV DG	
VI-0296	VERTICALE CERVICAL Tap 4.0 mm NAV DG c	
VI-0900	VERTICALE CERVICAL Nav Adapter clamp	
VI-0905	VERTICALE CERVICAL Nav Adapter Screw 1	
VI-0906	VERTICALE CERVICAL Nav Adapter Screw 2	
VI-0910	VERTICALE CERVICAL Nav Awl w stop	
VI-0920	VERTICALE CERVICAL Nav Probe, straight	
VI-0930.1	VERTICALE CERVICAL Nav PSD Basic Core	
VI-0930.2	VERTICALE CERVICAL Nav PSD Protection Sleeve	
VI-0930.3	VERTICALE CERVICAL NAV Inner Shaft	

Article Number	Description	Figure
VI-0940.1	VERTICALE CERVICAL NAV DG Basic Core	
VI-0940.2	VERTICALE CERVICAL NAV DG DS fixed	
VI-0940.3	VERTICALE CERVICAL NAV DG DS var	
VI-0940.4	VERTICALE CERVICAL DG DS	
VI-0941	VERTICALE CERVICAL Calibration Insert	



 **Silony Medical GmbH**

Leinfelder Strasse 60
70771 Leinfelden-Echterdingen
Germany
Tel +49 711 78 25 25 0
Fax +49 711 78 25 25 11
www.silonyspine.com

 elabeling.silony-medical.com/contact

D30285.a.EN 08.01.2026

 0483