

ROCCIA[®] PLIF POSTERIOR LUMBAR INTERBODY FUSION

INSTRUMENTATION GUIDE



MADE IN GERMANY

TABLE OF CONTENTS

Preface 3

Indications / Contraindications 4

ROCCIA PLIF – Instrumentation 5

PRODUCT INFORMATION 15

ROCCIA Implants PI 02

ROCCIA Trial Implants PI 03

ROCCIA Instruments PI 04

ROCCIA General Instruments PI 05

ROCCIA Alphabetical Index PI 06

NOTE: This Guide describes the instrumentation for ROCCIA PLIF – it does not replace briefing by a physician experienced in the surgical instrumentation of the spinal column.

We would be happy to assist you in finding a hospital that provides an opportunity to observe surgical procedures.

PREFACE

ROCCIA® PLIF – FOR LUMBAR SPINAL FUSION

The ROCCIA PLIF System was developed for primary stabilization and restoration of physiological lordosis in the lumbar spine.

The chamber system in the cage improves interbody fusion as its generously proportioned design allows for the insertion of either bone or bone graft materials. At the same time, the cage has a broad supporting surface that largely prevents sinking when implanted correctly.

The range of sizes of the sterile packed PLIF cages enables the treatment of a broad spectrum of pathologies in accordance with the individual patient's anatomy.

This not only helps to speed up the surgical procedure but also decreases the need for instrument sets which then have to be cleaned and stored in the hospital.

With interbody fusion using the ROCCIA PLIF System, we recommend the performance of additional posterior spondylodesis with instrumentation such as our VERTICALE posterior spinal fixation system.

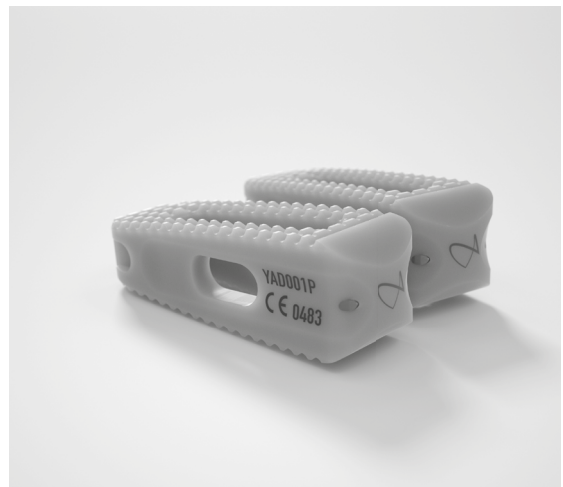

Indications

The ROCCIA PLIF System is indicated for interbody fusion with autogenous bone graft in patients with Degenerative Disc Disease (DDD) at one or two contiguous levels from L2 to S1. DDD patients may also have up to Grade 1 Spondylolisthesis or retrolisthesis at the involved levels. DDD is defined as discogenic back pain with degeneration of the disc confirmed by history or radiographic studies. These patients should be skeletally mature and have had six months of non-operative treatment. Additionally, the ROCCIA PLIF System is indicated in the setting of spinal deformity as a supplement to pedicle screw fixation in patients diagnosed with degenerative scoliosis. These implants may be implanted via an open posterior approach. These implants are to be used with autogenous bone graft. These devices are intended to be used with supplemental fixation instrumentation, which has been cleared by the FDA for use in the lumbar spine.

NOTE: Silony Medical recommends additional posterior fixation of the spinal segment being treated. The posterior screw-rod system from the VERTICALE product family for the thoracic and lumbar spine can be used for this purpose.

Contraindications

The use of implants for the following contraindications is considered to be improper use:

- Infection local to the operative site
- Signs of local inflammation
- Fever or leukocytosis
- Morbid obesity
- Pregnancy
- Mental illness
- Any other condition which would preclude the potential benefit of spinal surgery, such as the presence of tumors or congenital abnormalities, fracture local to the operating site, elevation of sedimentation rate unexplained by other diseases, elevation of white blood count (WBC), or a marked left shift in the WBC differential count
- Suspected or documented allergy or intolerance to composite materials
- Any case not needing a fusion
- Any case not described in the indications
- Any patient unwilling to cooperate with postoperative instructions
- Patients with a known hereditary or acquired bone friability or calcification problem should not be considered for this type of surgery
- These devices must not be used for pediatric cases, nor where the patient still has general skeletal growth
- Spondylolisthesis unable to be reduced to Grade 1
- Any case where the implant components selected for use would be too large or too small to achieve a successful result
- Any patients having inadequate tissue coverage over the operative site or inadequate bone stock or quality
- Any patient in which implant utilization would interfere with anatomical structures or expected physiological performance
- Prior fusion at the level(s) to be treated

NOTE: Please also note the advice about indications and contraindications from the instructions for use for ROCCIA PLIF. It also contains other important information that might lead to exclusion of the patient.

ROCCIA[®] PLIF INSTRUMENTATION

The following instrumentation steps apply for the standard access for ROCCIA PLIF.

Position and approach

The patient is positioned in the prone position, as is common for the posterior approach. Exposing the abdomen helps decrease the load on the abdominal vessels. Corresponding bearing frames or padding underneath the pelvis and thorax can be used for this purpose.

The main incision is usually performed medially above the spinous processes depending on the spinal segments being treated. The spinal erector muscles are then displaced strictly subperiosteally on both sides and dissected until the anatomical structures of the spinal column are clearly exposed (Fig. 1).

To expose the affected disc space, a partial facetectomy with corresponding laminotomy is necessary. After removal of the ligamentum flavum, the dura should be carefully held back in order to adequately expose the disc space.

It is recommended to protect the distal nerve root and the lateral dural margin with a blunt nerve hook during each of the following surgical steps. The annulus fibrosis is cut in rectangular sections and the posterior longitudinal ligament is partially resected to create a window of adequate size to the disc space (Fig. 2).

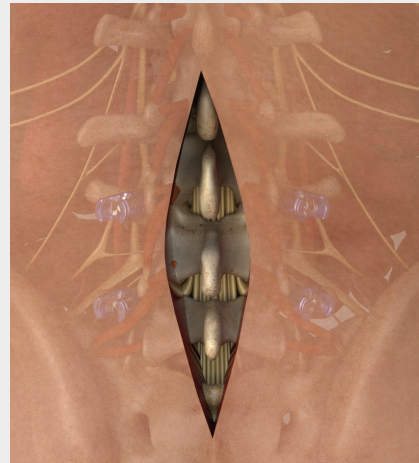

Fig. 1 Preparation until the anatomical structures can be clearly seen

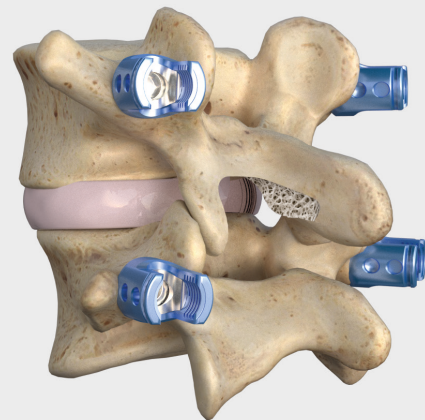

Fig. 2 Partial facetectomy until the disc space is adequately exposed

Discectomy

RI-1035
ROCCIA Box End Plate Scraper
Straight 6 mm



RI-3050
ROCCIA Rasp Straight



RI-3110*
ROCCIA Shaver, 10 mm, parallel



GI-3101
T-Handle



With a combination of shavers (Fig. 3), curettes (Fig. 4), and rasps (Fig. 5), a thorough discectomy is carried out. When carrying out the discectomy, ensure that the end plates remain intact.

To facilitate a thorough discectomy, adequate access to the intervertebral disc must be created. This can be aided by distraction. When using a distractor, it is inserted horizontally into the disc space and then rotated by 90 degrees. It is recommended to start with small sizes and to move to the required height step by step in accordance with the individual anatomy.

To prepare the end plates, curettes and rasps can be used. If necessary, a straight osteotome can be used for resection of the posterior edge of the upper and lower end plates to facilitate insertion of the cage.

* Representative of other shaver sizes
see ROCCIA Instruments

NOTE: Careful preparation of the disc space, especially extensive roughening of the end plates, provides the basis for better vascularization and successful bone fusion. Damage to the bony base and cover plate can lead to sinking of the implant into the vertebral body.

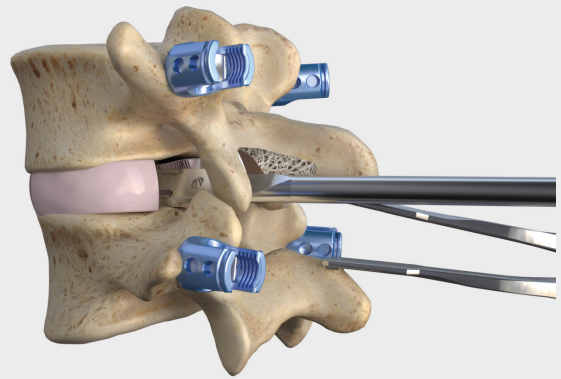

Fig. 3 Loosening of the disc material with a shaver

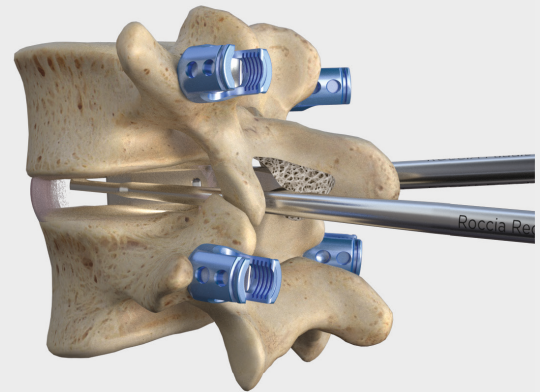

Fig. 4 Box end plate scraper for extensive removal of disc material

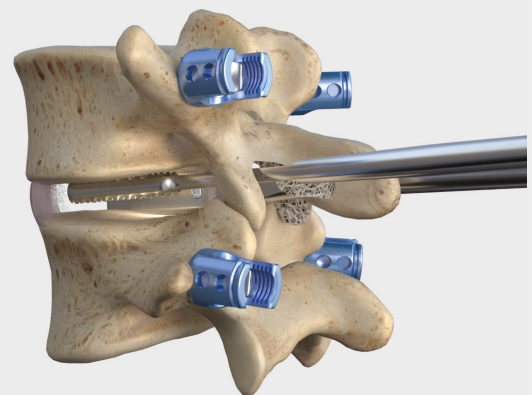

Fig. 5 Straight rasp for roughening the cover plates

Distracting the disc space

RI-3210*
ROCCIA Distractor 10 mm,
parallel



GI-3101
T-Handle



The ROCCIA PLIF System offers a broad selection of different sizes, lengths, angles, and heights. This enables the individual selection of the implant in accordance with the anatomical situation and the desired reconstruction of the spinal segment.

Blunt distractors with depth markings (23, 28, and 33 mm) are available to determine the size of the disc space. The smallest cage size can be determined through a drill hole and the sizes 28 mm and 33 mm using the markings with lateral monitoring using an image converter (Fig. 6).

The contralateral side can be distracted in the same move. If the distractor remains in place, this simplifies the insertion of the trial implant and the cage.

The distractors can also be used to restore the intersegmental height.

Additional distraction is also achieved before the insertion of the ROCCIA PLIF using the corresponding trial implant.

* Representative of other distractor sizes, see ROCCIA Instruments

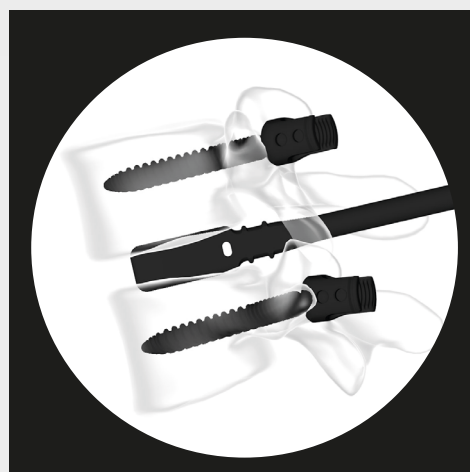
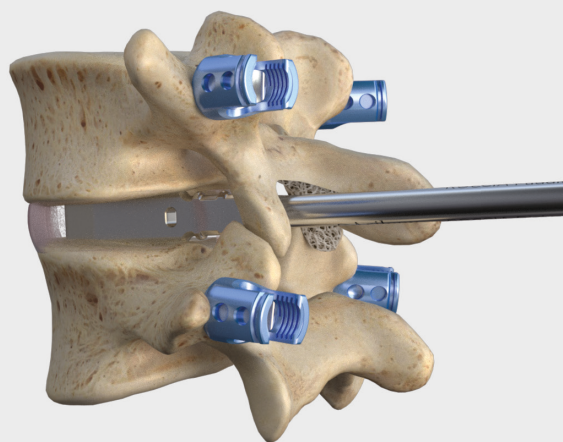

Fig. 6 Spreading the disc space with the distractor; image converter monitoring using the depth markings for length determination of the trial or the cage

NOTE: Overdistraction should be avoided. This increases the risk of damage to the base and cover plates and subsequent sinking of the implant and jeopardizes the restoration of physiological lordosis.

Selecting the trial implant

RI-3010
ROCCIA PLIF Inserter,
dismountable



RI-T11112305
ROCCIA PLIF Trial height
11 mm, 23–33 mm, 5°



RI-3210*
ROCCIA Distractor 10 mm,
parallel



GI-3101
T-Handle



The trial implants combine all three possible implant lengths, 23, 28, and 33 mm, in the particular height. All trials have an angle of 5°. The trial implants correspond to the subsequent ROCCIA PLIF size without interlock. If larger lordosis is desired in the imaging converter monitoring, the implant is also available with 10° lordosis angle.

The height of the cage interlock on the definitive implant was taken into account when selecting the trial implants. Silony Medical recommends selecting an implant that is as wide as possible in order to achieve a broad contact surface area and ensure support on the anterior and posterior cortical region of the end plates. Using the image converter, the length is determined using the X-ray markings on the trial implant which display the different lengths in the lateral X-ray (Fig. 7).

To determine the implant height, it is important to make sure that the trial implant sits neither too tight nor too loose. Accordingly, a smaller or larger version should be tried out until the trial implant is seated stably in the intersegmental space.

* Representative of other distractor sizes, see ROCCIA Instruments

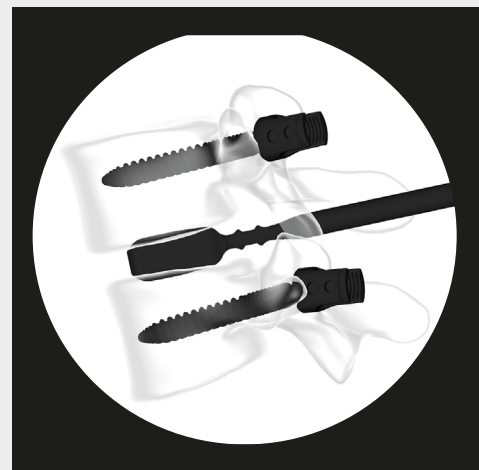
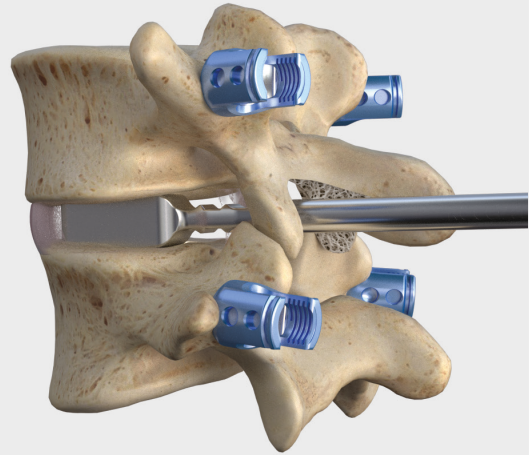

Fig. 7 Insertion of the trial to determine the size of the implant

NOTE: The trial implant also serves to simulate the insertion of the implant into its final position. If the trial implant cannot be brought into its desired end position, then further preparation of the intervertebral disc space may be necessary.

NOTE: The trial implant has a smooth surface and its height corresponds to the ROCCIA PLIF Cage without interlock. This means that slightly more force is required to insert the cage. However, the arrangement of the teeth in turn supports the orientation of the implant during insertion.

Filling of the cage

RI-3010
ROCCIA PLIF Inserter, dismountable



RI-2070
ROCCIA PLIF Loading Block



RI-2051
ROCCIA
Bone Graft Pusher



Remaining areas of the intervertebral disc space can be filled with autogenous bone (e.g., from the iliac crest), before or after implantation of the cage in order to achieve the largest possible fusion surface area. Filling of the disc space, but also filling of the implant, is an important prerequisite for secure fusion. A loading block and a pusher are provided for this (Fig. 8).

The cage can be filled with or without the mounted inserter. If the cage is filled without a mounted inserter, the loading block provides holding spaces for each cage width. These act where required as interim storage for unmounted cages or as a storage option for placing and mounting the inserter. Cages can be inserted into this interim storage in only one direction with the tip downward so that the posterior adjacent drill hole is facing upward.

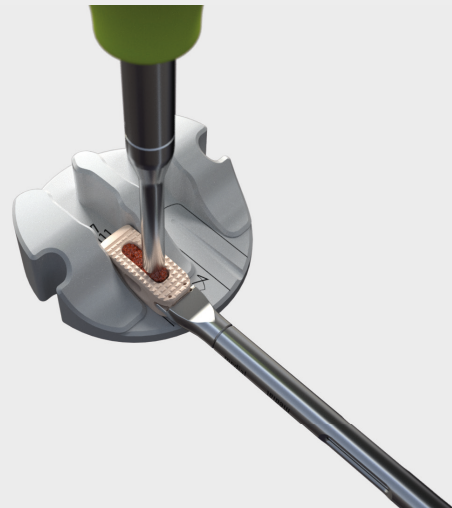

Fig. 8 Filling the cage with bone material in the loading block with pusher

Inserting the cage

RI-3010
ROCCIA PLIF Inserter, dismountable



RI-1355
ROCCIA Slotted Mallet, solid



The ROCCIA PLIF Inserter is screwed into the threaded holes of the cage, enabling the cage to be definitively inserted without requiring any further instrument change. To create a firm seat between the cage and the inserter, the rotating handle of the inserter is turned toward the locked padlock (Fig. 9). To loosen the cage, the rotating handle is turned toward the open padlock (Fig. 10).

The autologous bone material must be inserted well compressed into the cage. The trial implant is removed just shortly before final insertion of the implant in order to prevent subsequent sinking.

The filled implant is carefully inserted into the disc space and the correct alignment of the implant is verified. Slight pressure or careful hammering with the ROCCIA Slotted Mallet on the inserter may be required.

The cage is inserted into the disc space under X-ray control. The neurogenic structures should be protected when doing so.

The slightly conical tip of the implant helps with the entry into the intervertebral disc space by slightly distracting the rear edge. If required for better insertion of the cage, additional distraction can be achieved using the pedicle screws.

Before positioning the second cage, the anterior and medial side of the intervertebral space should also be filled with autologous cancellous bone or a bone graft material.

After the final positioning of the implant, the inserter is unscrewed from the cage and removed.

This suggestion is accordingly repeated on the contralateral side.

NOTE: Final positioning or subsequent hammering of the cage with the inserter may only be carried out if it has been either fully mounted or the core has been removed. Otherwise, the threaded bore of the cage or the instrument connection thread may be damaged.

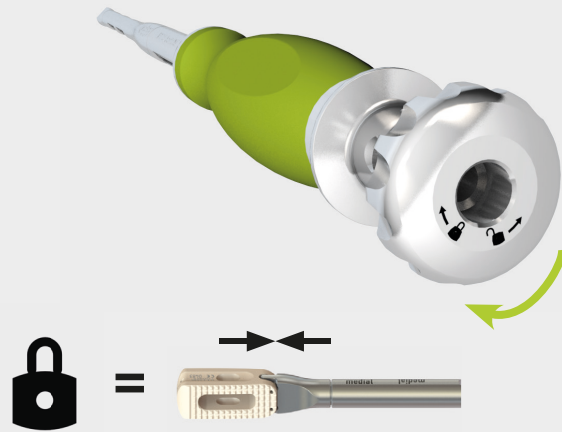

Fig. 9 Turning in the direction of the closed padlock connects the inserter firmly with the cage

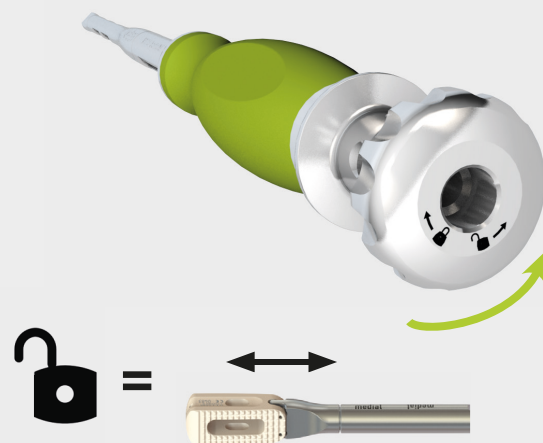

Fig. 10 Turning in the direction of the open padlock detaches the cage from the inserter

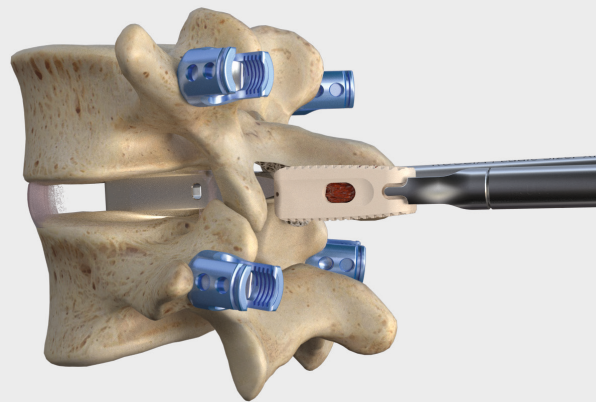

Fig. 11 Inserting the filled cage into the disc space

Correct position of the ROCCIA® PLIF

The final position of the implants (Fig. 12) should be checked using the image intensifier (in lateral and anterior-posterior view). X-ray markers in the implant reveal the position of the cage (Fig. 13).

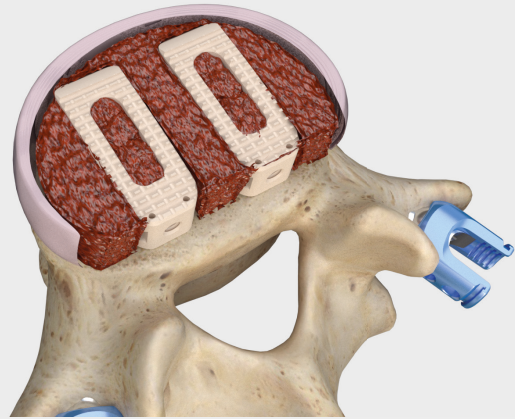

Fig. 12 Optimal position of the filled PLIF Cage

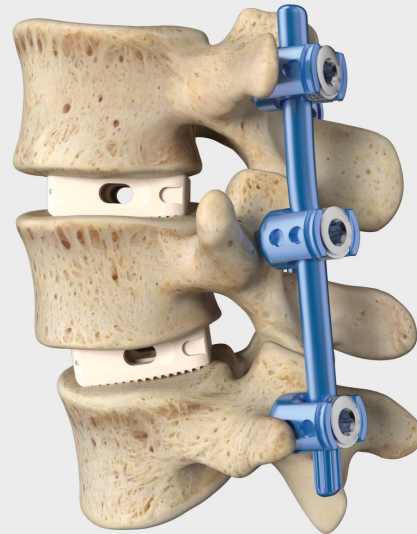

Fig. 13 Optimal position of the filled PLIF Cage including posterior fixation

NOTE: Posterior stabilization with the VERTICALE Posterior Spinal Fixator is recommended (or posterior or anterior securing of the implant when using the anterior approach). Tension band wiring supports the biomechanical stability of the motion segment and the stability of the ROCCIA PLIF Cage. The final steps of posterior fixation (e.g., insertion of the rod, compression, and final tightening of the set screws) are completed after implantation of the cage.

CORRECTING THE POSITION OF THE ROCCIA® PLIF CAGE

The functional inserter is available for the final positioning of the ROCCIA PLIF Cage. The use of the inserter is outlined below.

Insertor as a driver

RI-3010
ROCCIA PLIF Insertor, dismountable



RI-1355
ROCCIA Slotted Mallet, solid



The insertor can be used in a range of ways: Using the rotating handle, the two instrument components can be disassembled so that both individual components are available for use. The body can be attached to the cage again after removal of the core and used as a driver by striking the instrument directly with the hammer. This allows the cage to be positioned more anteriorly. The driving should be carried out under monitoring with the image converter.



Fig. 14 Insertor functioning as a driver

Insertor as a revision instrument

RI-3010
ROCCIA PLIF Insertor, dismountable



RI-1355
ROCCIA Slotted Mallet, solid



To be able to remove the ROCCIA PLIF implant again, the inner core can be used. The core contains the thread for the cage connection and is now attached to the cage and firmly tightened. A revision of a cage requires that the instrument is screwed in to the stop. Using gentle, controlled impacts with the slotted mallet below the handle attachment, the cage can now undergo revision.

NOTE: The neurogenic structures should be protected when doing so.



Fig. 15 Insertor functioning as a revision instrument

ROCCIA® PLIF PRODUCT INFORMATION

ROCCIA PLIF Implants by article number	PI 02
ROCCIA PLIF Trial Implants by article number	PI 08
ROCCIA Instruments by article number	PI 10
ROCCIA General Instruments by article number	PI 14
ROCCIA Alphabetical Index	PI 15

ROCCIA® PLIF Implants

Article number explanation for the cage, as an example

ROCCIA PLIF Cage, 9 × 11 × 28, 10° lordosis

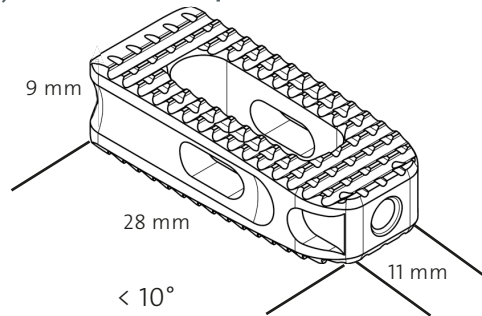

System:
ROCCIA

Implant type:
PLIF

Typing:
23 mm

Material:
PEEK
Tantalum (x-ray marker)

Article number	Description	Illustration
S-RPP-08112305-S	ROCCIA PLIF Cage, 8 × 11 × 23 mm, 5° lordosis	
S-RPP-08112310-S	ROCCIA PLIF Cage, 8 × 11 × 23 mm, 10° lordosis	
S-RPP-10112305-S	ROCCIA PLIF Cage, 10 × 11 × 23 mm, 5° lordosis	
S-RPP-10112310-S	ROCCIA PLIF Cage, 10 × 11 × 23 mm, 10° lordosis	
S-RPP-12132305-S	ROCCIA PLIF Cage, 12 × 13 × 23 mm, 5° lordosis	
S-RPP-12132310-S	ROCCIA PLIF Cage, 12 × 13 × 23 mm, 10° lordosis	

System:
ROCCIA

Implant type:
PLIF

Typing:
28 mm

Material:
PEEK
Tantalum (x-ray marker)

Article number	Description	Illustration
S-RPP-07112805-S	ROCCIA PLIF Cage, 7 × 11 × 28 mm, 5° lordosis	
S-RPP-08112805-S	ROCCIA PLIF Cage, 8 × 11 × 28 mm, 5° lordosis	
S-RPP-09112805-S	ROCCIA PLIF Cage, 9 × 11 × 28 mm, 5° lordosis	
S-RPP-09112810-S	ROCCIA PLIF Cage, 9 × 11 × 28 mm, 10° lordosis	
S-RPP-10112805-S	ROCCIA PLIF Cage, 10 × 11 × 28 mm, 5° lordosis	
S-RPP-10112810-S	ROCCIA PLIF Cage, 10 × 11 × 28 mm, 10° lordosis	
S-RPP-11112805-S	ROCCIA PLIF Cage, 11 × 11 × 28 mm, 5° lordosis	
S-RPP-11112810-S	ROCCIA PLIF Cage, 11 × 11 × 28 mm, 10° lordosis	
S-RPP-12132805-S	ROCCIA PLIF Cage, 12 × 13 × 28 mm, 5° lordosis	
S-RPP-12132810-S	ROCCIA PLIF Cage, 12 × 13 × 28 mm, 10° lordosis	
S-RPP-14132805-S	ROCCIA PLIF Cage, 14 × 13 × 28 mm, 5° lordosis	
S-RPP-14132810-S	ROCCIA PLIF Cage, 14 × 13 × 28 mm, 10° lordosis	

ROCCIA® PLIF Implants

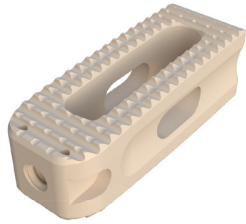
Article number	Description	Illustration
S-RPP-08113305-S	ROCCIA PLIF Cage, 8 × 11 × 33 mm, 5° lordosis	
S-RPP-10113305-S	ROCCIA PLIF Cage, 10 × 11 × 33 mm, 5° lordosis	
S-RPP-10113310-S	ROCCIA PLIF Cage, 10 × 11 × 33 mm, 10° lordosis	
S-RPP-12133305-S	ROCCIA PLIF Cage, 12 × 13 × 33 mm, 5° lordosis	
S-RPP-12133310-S	ROCCIA PLIF Cage, 12 × 13 × 33 mm, 10° lordosis	
S-RPP-14133305-S	ROCCIA PLIF Cage, 14 × 13 × 33 mm, 5° lordosis	
S-RPP-14133310-S	ROCCIA PLIF Cage, 14 × 13 × 33 mm, 10° lordosis	

System:
ROCCIA

Implant type:
PLIF

Typing:
33 mm

Material:
PEEK
Tantalum (x-ray marker)

ROCCIA® PLIF Trial Implants

Article number	Description	Illustration
RI-T07112305	ROCCIA PLIF Trial height 7 mm, 23–33 mm, 5°	
RI-T08112305	ROCCIA PLIF Trial height 8 mm, 23–33 mm, 5°	
RI-T09112305	ROCCIA PLIF Trial height 9 mm, 23–33 mm, 5°	
RI-T10112305	ROCCIA PLIF Trial height 10 mm, 23–33 mm, 5°	
RI-T11112305	ROCCIA PLIF Trial height 11 mm, 23–33 mm, 5°	
RI-T12132305	ROCCIA PLIF Trial height 12 mm, 23–33 mm, 5°	
RI-T14132305	ROCCIA PLIF Trial height 14 mm, 23–33 mm, 5°	
RI-T16132305	ROCCIA PLIF Trial height 16 mm, 23–33 mm, 5°	

System:
ROCCIA

Instrument type:
Trial implant

Typing:
23-33 mm



Material:
Ti6Al4V ELI

ROCCIA® Instruments

Article number	Description	Illustration	Page
RI-1035	ROCCIA Box End Plate Scraper Straight 6 mm		7
RI-1330	ROCCIA Removal Adapter		no illustration
RI-1355	ROCCIA Slotted Mallet, solid		11, 14
RI-2051	ROCCIA Bone Graft Pusher		10
RI-2070	ROCCIA PLIF Loading Block		10
RI-3010	ROCCIA PLIF Inserter, dismantable		9, 10, 11, 14
RI-3050	ROCCIA Rasp Straight		7
RI-3107	ROCCIA Shaver 7 mm, parallel		7
RI-3108	ROCCIA Shaver 8 mm, parallel		
RI-3109	ROCCIA Shaver 9 mm, parallel		
RI-3110	ROCCIA Shaver 10 mm, parallel		
RI-3111	ROCCIA Shaver 11 mm, parallel		
RI-3112	ROCCIA Shaver 12 mm, parallel		
RI-3114	ROCCIA Shaver 14 mm, parallel		
RI-3116	ROCCIA Shaver 16 mm, parallel		

Article number	Description	Illustration	Page
RI-3207	ROCCIA Distractor 7 mm, parallel		8, 9
RI-3208	ROCCIA Distractor 8 mm, parallel		
RI-3209	ROCCIA Distractor 9 mm, parallel		
RI-3210	ROCCIA Distractor 10 mm, parallel		
RI-3211	ROCCIA Distractor 11 mm, parallel		
RI-3212	ROCCIA Distractor 12 mm, parallel		
RI-3214	ROCCIA Distractor 14 mm, parallel		
RI-3216	ROCCIA Distractor 16 mm, parallel		

General Instruments

Article number	Description	Illustration	Page
GI-3201	Handle		7, 8, 9, 11, 14
GI-3101	T-Handle		

ROCCIA® Alphabetical Index

A-Z	Description	Article number	Page
B	Bone Graft Pusher	RI-2051	10
	Box End Plate Scraper Straight 6 mm	RI-1035	7
D	Distractor 7 mm, parallel	RI-3207	8, 9
	Distractor 8 mm, parallel	RI-3208	
	Distractor 9 mm, parallel	RI-3209	
	Distractor 10 mm, parallel	RI-3210	
	Distractor 11 mm, parallel	RI-3211	
	Distractor 12 mm, parallel	RI-3212	
	Distractor 14 mm, parallel	RI-3214	
Distractor 16 mm, parallel	RI-3216		
H	Handle	GI-3201	no illustration
I	Insertor, dismountable	RI-3010	9, 10, 11, 14
L	Loading Block	RI-2070	10
R	Rasp Straight	RI-3050	7
	Removal Adapter	RI-1330	no illustration
S	Slotted Mallet, solid	RI-1355	11, 14
	Shaver 7 mm, parallel	RI-3107	7
	Shaver 8 mm, parallel	RI-3108	
	Shaver 9 mm, parallel	RI-3109	
	Shaver 10 mm, parallel	RI-3110	
	Shaver 11 mm, parallel	RI-3111	
	Shaver 12 mm, parallel	RI-3112	
	Shaver 14 mm, parallel	RI-3114	
Shaver 16 mm, parallel	RI-3116		
T	T-Handle	GI-3101	7, 8, 9, 11, 14
	Trial height 7 mm, 23–33 mm, 5°	RI-T07112305	9, PI 03
	Trial height 8 mm, 23–33 mm, 5°	RI-T08112305	
	Trial height 9 mm, 23–33 mm, 5°	RI-T09112305	
	Trial height 10 mm, 23–33 mm, 5°	RI-T10112305	
	Trial height 11 mm, 23–33 mm, 5°	RI-T11112305	
	Trial height 12 mm, 23–33 mm, 5°	RI-T12132305	
	Trial height 14 mm, 23–33 mm, 5°	RI-T14132305	
	Trial height 16 mm, 23–33 mm, 5°	RI-T16132305	

A series of horizontal dotted lines for writing notes.

Notes

A series of horizontal dotted lines for writing notes.



www.silony-medical.com

 **Silony Medical Corp.**
8200 NW 27th Street, Suite 104
Doral, FL 33122, USA
Phone +1 305 916 0016

 **Silony Medical GmbH**
Leinfelder Strasse 60
70771 Leinfelden-Echterdingen
Tel +49 711 78 25 25 0
Fax +49 711 78 25 25 11

This information is only intended for the USA and its territories.

D60015.a.EN 09.01.2020