

VERTICALE® WINX®

INSTRUMENTATION GUIDE

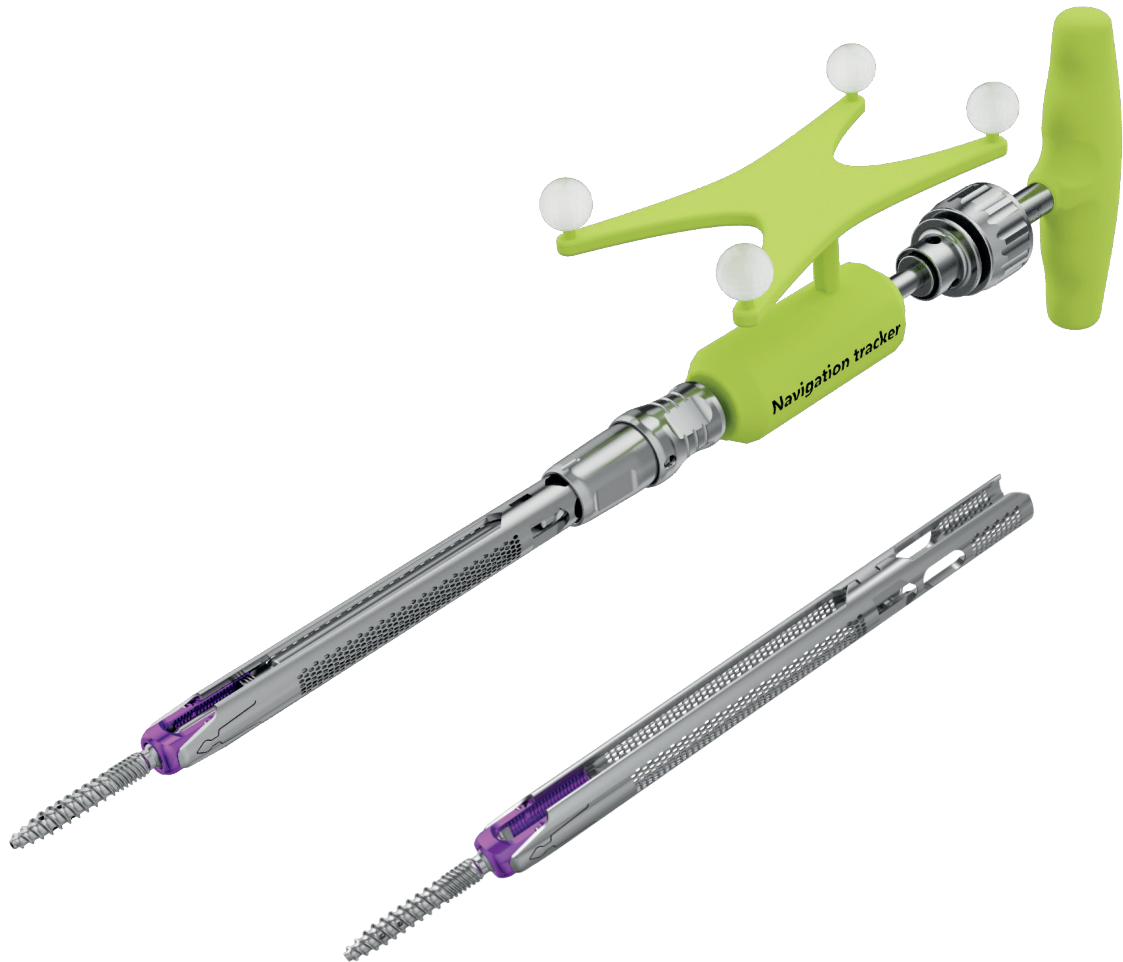

MADE IN GERMANY

TABLE OF CONTENTS

Preface 3

Indications / contraindications 4

INSTRUMENTATION 5

 Position and approach 6

 Localization of the pedicle 6

 Incision and dilation 7

 Preparation of the pedicle 7

 Selection of pedicle screws 8

 Assembly of pedicle screws with the WINX Blades 9

 Assembly of pedicle screws with the WINX Tower (optional) 10

 Disengaging and removal of the WINX Tower 11

 Preparation of the pedicle screwdriver and screw attachment 12

 Pedicule Screw Placement 13

 Aligning the screw heads 14

 Rod selection 15

 Insertion of the rods 16

 Positioning the rods in the screw head 17

 Temporary fixation of the set screw 18

 Compression and distraction 18

 Reduction maneuver 19

 Final tightening 19

 Removal of the WINX Blades 20

 Revision of Implants 21

PRODUCT INFORMATION 22

Implants PI 02 - PI 08

Instruments PI 09

Alphabetical index PI 11

NOTE: This Guide describes the instrumentation for the VERTICAL MIS system combined with the WINX system — it does not replace briefing by a physician experienced in the surgical instrumentation of the spinal column. We would be happy to assist you in finding a hospital that provides an opportunity to observe surgical procedures.

NOTE: The WINX system is compatible with leading navigation systems. The Navigation tracker shown in this instrumentation guide is representative for a variety of general navigation tracker customary in the market. Please refer to the VERTICALE Navigation Instrumentation Guide D60063 for more information.

PREFACE

VERTICALE[®] – WINX[®]

VERTICALE is a posterior rod-screw fixation system for stabilizing the thoracic and lumbar spine.

The VERTICALE WINX System is an extension of the VERTICALE MIS system and the basic posterior spinal fixation system.

The system was developed in close cooperation with experienced and qualified spinal surgeons as well as specialist staff from OR and sterilization departments. As a result, VERTICALE is a highly developed, modular, and versatile fixation system.

VERTICALE WINX and MIS are system enhancements consisting of instruments and implants that allow the VERTICALE Screw Rod Fixation System to be used in minimally invasive techniques.

Adhering to our Clinically Driven design philosophy, the VERTICALE System is a living system. Whether instrument or implant—we are constantly working to expand and improve our systems in order to optimally meet the needs of patients, physicians, and hospital nursing staff.



Indications

The VERTICALE MIS System is indicated for use in the thoracic and lumbar spine as well as for iliosacral fixation procedures (T1–S2 / ilium).

This includes a wide range of thoracic and lumbar instabilities that require comprehensive posterior pedicle screw fixation:

- Degenerative disc diseases
- Spondylolisthesis of all etiologies
- Stenosis
- Deformities such as scoliosis and kyphosis
- Fractures
- Spondylitis
- Tumors
- Revisions
- Pseudarthrosis

NOTE: Anterior interbody support in the form of an intervertebral implant device, such as a ROCCIA cage, is recommended for treating instabilities of the anterior spine and is used at the discretion of the operating surgeon and in accordance with the respective indication.

Contraindications

Under certain circumstances, implantation is contraindicated or associated with substantial risks, even though there may be an indication. These include in particular:

- Anticipated or documented allergy or intolerance to the materials used (e.g., titanium or cobalt chromium)
- Any case in which the chosen implants would be too large or too small to achieve a successful result
- Any patient for whom the use of the implant would conflict with anatomical structures
- Missing bony structures that make solid anchoring of the implant impossible (e.g., in the case of fractures, tumors, or osteoporosis).

NOTE: Please also note the Instructions for Use provided with each product. They may include additional advice that leads to exclusion of the implant procedure.

VERTICALE® WINX® INSTRUMENTATION GUIDE

In the following section only the particular steps required for the use of the VERTICALE WINX System for monosegmental posterior VERTICALE MIS standard instrumentation will be described. Multisegmental instrumentations are also performed according to these instructions. Refer to the VERTICALE MIS Instrumentation Guide for the use of the standard VERTICALE MIS instruments.

Position and approach

The patient is positioned in the prone position for the posterior approach. Corresponding bearing frames or padding underneath the pelvis and thorax can be used for this purpose. The VERTICALE MIS System and WINX System supports both percutaneous and paraspinal access. It is the responsibility of the attending surgeon to select the approach in accordance with experience and preference. Using an image intensifier for verification, the pedicles are localized and the position of the incision determined on the skin. The required incisions of the skin and fasciae are carried out in accordance with the selected approach. Blunt dissection of the soft tissue is then carried out in order to establish initial access to the pedicle.

Localization of the pedicle

The pedicle is localized using the Jamshidi needle and in accordance with the VERTICALE MIS System Instrumentation Guide D60005.



Fig. 1 Dilation with VI-4020 VERTICALE MIS Dilation Sleeve F-Wire

NOTE: The placement of the guide wire using a Jamshidi needle depends on the preference of the attending surgeon.

NOTE: Ensure that the inserted guide wires remain in position throughout the entire instrumentation. This should be monitored using an image intensifier for verification to prevent perforation of the anterior wall of the vertebral body and injury to the vessels in front.

Incision and dilation

For further dilation, the individual VERTICALE MIS Dilators are placed in sequence on top of one another. Proceed according to the VERTICALE MIS System Instrumentation Guide D60005.



Fig. 2 Dilation of 20 mm

Preparation of the pedicle

The cannulated VERTICALE MIS Awl is used to additionally open up the pedicle down to the cancellous bone of the vertebral body. Guide the awl via the wire and, using an image intensifier for verification, open the pedicle down to the vertebral body. Again, proceed according to the VERTICALE MIS System Instrumentation Guide D60005.

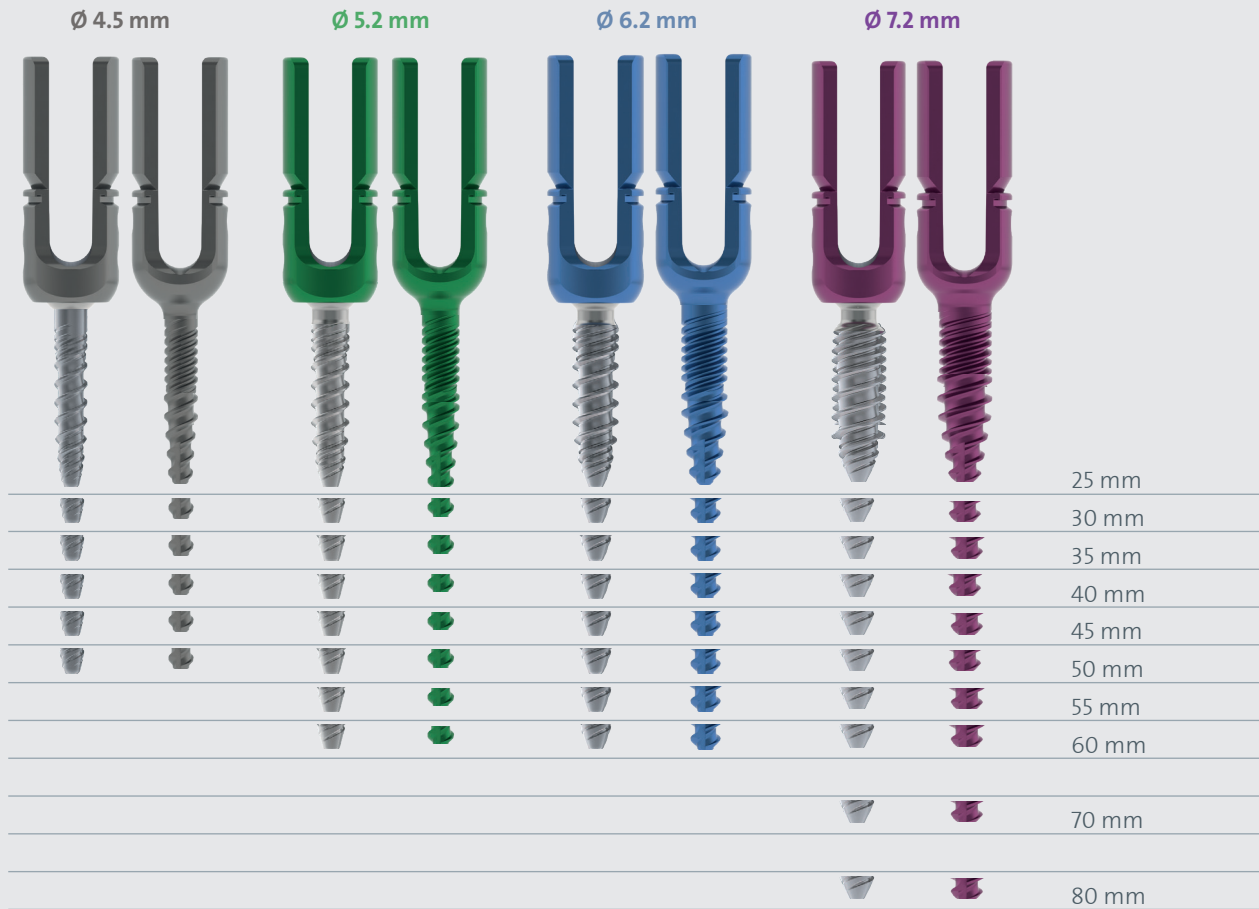

Fig. 3 Opening of the pedicle using the VERTICALE MIS Probe

Selection of pedicle screws

To enable faster and easier identification, all VERTICALE Pedicle Screws are color-coded by diameter. The length gradations are in 5-mm increments.

The WINX System can be used with all cannulated polyaxial, uniplanar, and monoaxial reduction screws.



* Further screws are shown in the chapter "Implants".

NOTE: Using an image intensifier to perform anterior verification, select pedicle screws with the largest possible diameter, based on the pedicle diameter. The length of the screw should be selected so that it extends to at least 2/3 of the diameter of the vertebral body, ideally up to the anterior edge of the vertebral body. A sacral screw fixation should be barely bicortical (perforation of the anterior cortex with at most one thread).

Assembly of pedicle screws with the WINX® Blades

VI-4412
VERTICALE WINX Blade 2.0



VERTICALE WINX Blades are guided into each other along the tabs and clipped together on the sides of the pedicle screw head (Fig. 4).

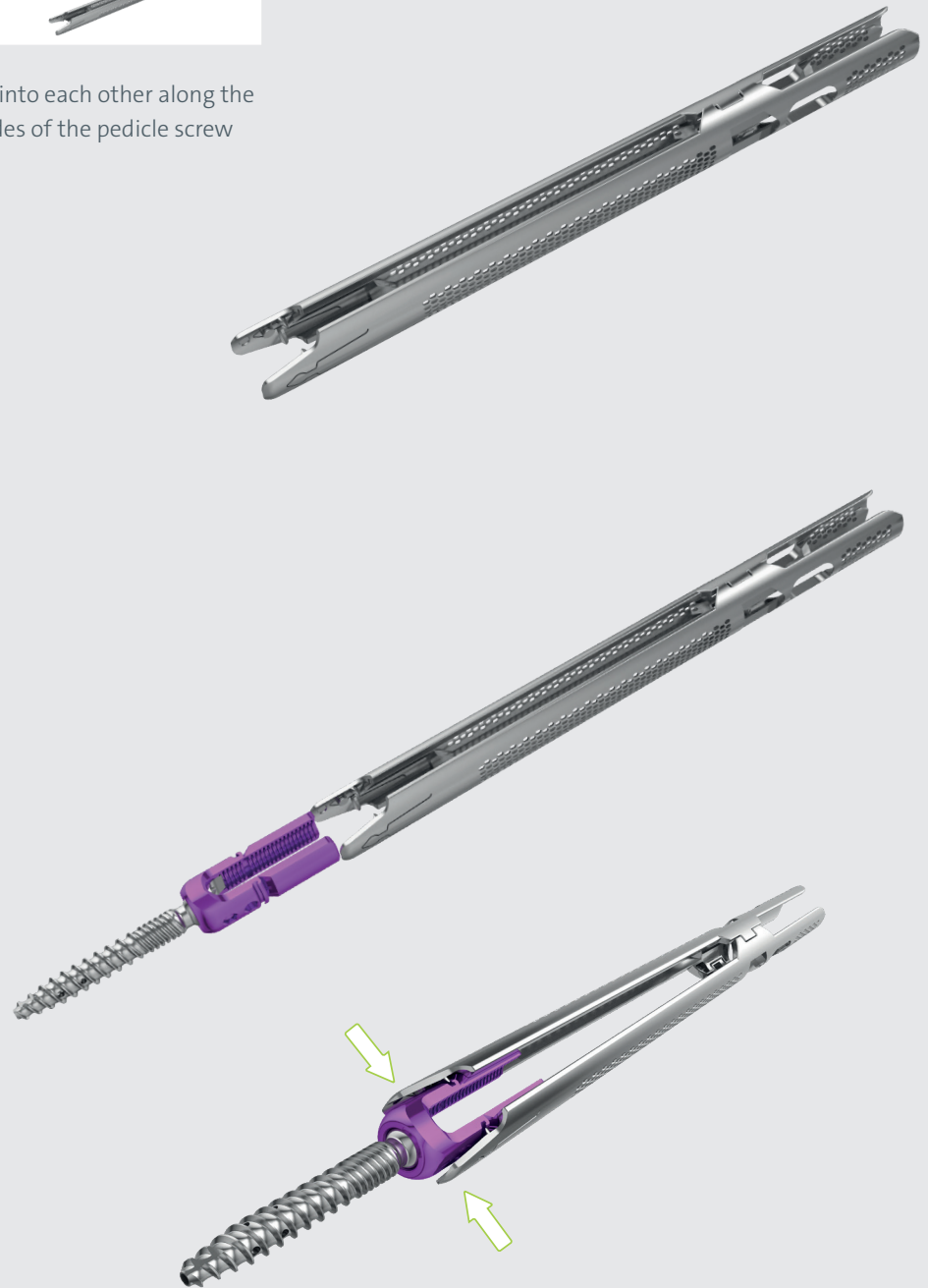

NOTE: Check that the VERTICALE WINX Blades are firmly seated on the pedicle screw. Ensure that the wings of the VERTICALE WINX Blades are interlocked, otherwise the VERTICALE WINX Towers cannot be adapted. The lock spring must lie flush with the pedicle head and on the outer contour of the WINX Blade.

Fig. 4 WINX Blades have to connect at the flanks.

Assembly of pedicle screws with the WINX[®] Tower (optional)

VI-4422
VERTICALE WINX Tower 2:0



To increase the stability of the VERTICALE WINX Blade construction, a VERTICALE WINX Tower can be guided over the VERTICALE WINX Blades (Fig. 5). To do so, guide the VERTICALE WINX Tower over the VERTICALE WINX Blades until an audible click is heard. The VERTICALE WINX Tower has an automatic depth stop as well as automatic engagement. The external diameter, length, and other connections of the VERTICALE WINX Tower are compatible with the conventional VERTICALE MIS Working Tower (see the VERTICALE MIS System Instrumentation Guide D60005).



Fig. 5 Assembly of the VERTICALE WINX Tower over the VERTICALE WINX Blades.

NOTE: For forceful maneuvers, the VERTICALE WINX Tower must be used because otherwise there is a risk that the VERTICALE WINX Blades detach from the screw.

NOTE: All correction maneuvers shown in the VERTICALE MIS System Instrumentation Guide D60005 can be made with these VERTICALE WINX Towers. Refer to the Instrumentation Guide D60005 for more information about the correction maneuvers.

NOTE: The VERTICALE WINX Tower can be assembled at any time. That is, the VERTICALE WINX Tower can be attached either ex-situ by the scrub tech or in-situ by the surgeon, providing flexibility and control when needed.

Disengaging and removal of the WINX® Tower

VI-4422
VERTICALE WINX Tower 2.0



To remove the VERTICALE WINX Tower, press the two VERTICALE WINX Blades protruding from the VERTICALE WINX Tower together. The engagement is now deactivated and the VERTICALE WINX Tower can be withdrawn.



Fig. 6 Disengage and remove the VERTICALE WINX Tower.

Preparation of the pedicle screwdriver and screw attachment

V-4440
VERTICALE WINX Screwdriver



GI-3111
Ratchet T-Handle



For attachment of the pedicle screw, the VERTICALE WINX Screwdriver is inserted into the inner Torx of the screw shaft between the VERTICALE WINX Blades. After that, the internal thread of the screw head is connected to the external thread of the instrument by rotating to the right (on the metal handle) and applying slight downward pressure (Fig. 7). Please make sure the connection is secure. In doing so, ensure that orthograde alignment is maintained between the screw shaft and the screwdriver construction.

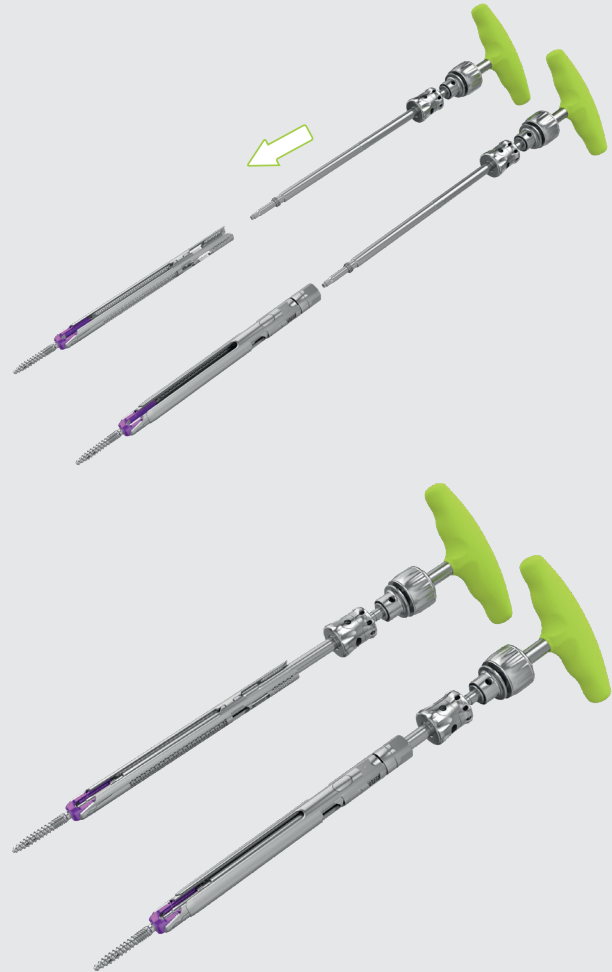

Fig. 7 Screw in the VERTICALE WINX Screwdriver onto a pedicle screw.

NOTE: When using a VERTICALE WINX Tower, proceed in the same way.

Pedicle Screw Placement

VI-1060
Guide wire with trocar tip



VI-4024
VERTICALE MIS Dilator 4
(20 mm)



Guide the prepared pedicle screwdriver via the guide wire and through the Verticale MIS Dilator 4 (20 mm). Ensure that the insertion axis of the pedicle screw corresponds with the guide wire.

Using an image intensifier for verification, the VERTICALE pedicle screws are screwed into the prepared screw channel until the screw shaft is fully inserted into the pedicle. Verify the position and alignment of the guide wire that protrudes from the handle of the pedicle screwdriver.

As soon as the tip of the shaft of the pedicle screw enters the vertebral body, remove the guide wire. Continue to insert the pedicle screw to the required position in the vertebral body. The screwdriver can be disengaged from the screw and the VERTICALE WINX Blades.

Remove the VERTICALE MIS Dilator.

This process is repeated until all pedicle screws have been positioned with the respective VERTICALE WINX Blades. Verifying the correct positioning of the pedicle screws by means of an image intensifier in frontal and sagittal projection is strongly recommended.

NOTE: In the case of polyaxial screws, ensure that the polyaxiality of the screw head is not blocked. When using monoaxial and uniplanar screws, it must be ensured that the screw head is aligned in a superior-inferior direction. If necessary, the screw must be turned back a little.

NOTE: Using monoaxial screws may hinder the procedure using the VERTICALE WINX System because the VERTICALE WINX Blades are always aligned orthograde to the pedicle screw. In the event of severe lordosis, for example, this may result in the alignment of VERTICALE WINX Blades preventing the application of additional VERTICALE WINX Blades.

Aligning the screw heads

GI-3101
T-Handle



VI-4470
VERTICALE WINX Tulip Adj. +
Rod Feeler



The pedicle screw heads are adjusted with the VERTICALE WINX Tulip Adj. + Rod Feeler. The adjuster is placed into the screw head and can then be used to align the screw depending on how the rod will subsequently be inserted (Fig. 8).

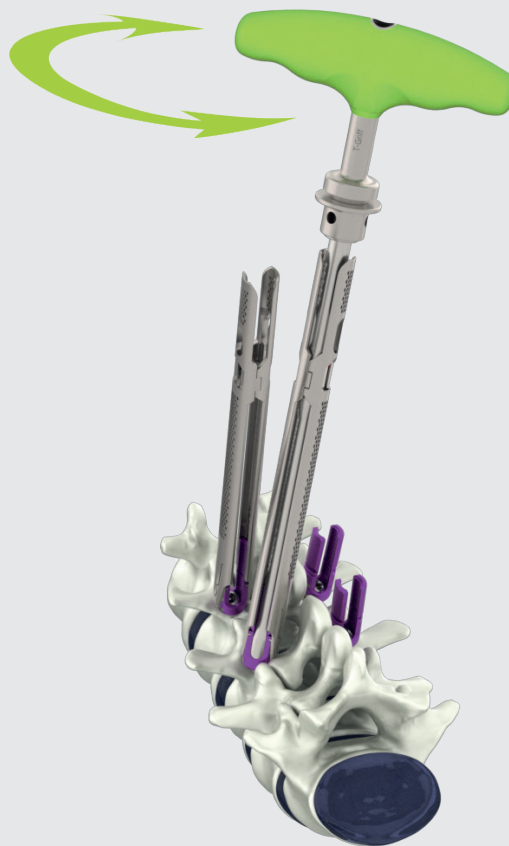

Fig. 8 Aligning the pedicle screw head with the VERTICALE WINX Tulip Adj. + Rod Feeler

NOTE: When the VERTICALE WINX Tower is used, the VERTICALE MIS Counter Torque can also be used for alignment.

Rod selection

VI-4060
VERTICALE MIS Rod Gauge



VI-4061
VERTICALE MIS
Rod Length Verifier



All VERTICALE MIS rods have a conical tip for aiding positioning and are available curved or straight. A comprehensive range of rod lengths with a diameter of 5.5 mm are available. Details can be found in the appended product information sheets; see Implants.

The required rod length is determined using the VERTICALE MIS Rod Gauge and the MIS Rod Length Verifier (Fig. 9-10b). Proceed according to the VERTICALE MIS System Instrumentation Guide D60005.



Fig. 9 Determine the rod length using the VERTICALE MIS Rod Gauge.

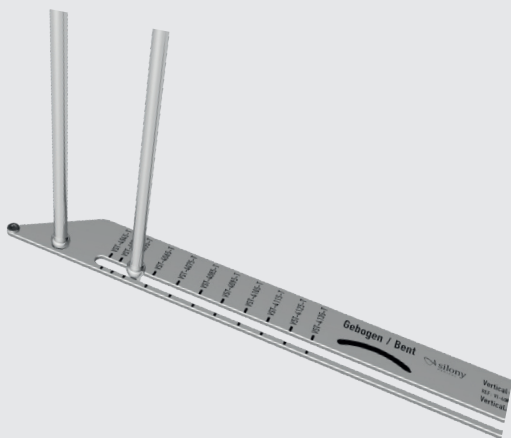

Fig. 10a Reading the rod length on the rod length verifier

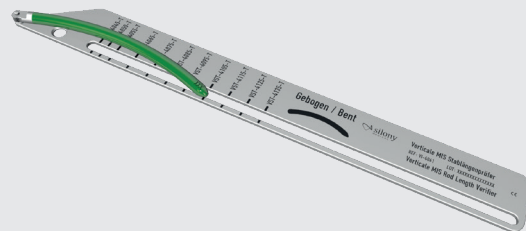

Fig. 10b Verifying the length of the MIS Rods on the rod length verifier

Inserting the rods

The preparation and insertion of the MIS Rods with the fixed VERTICALE MIS Rod Inserter and the adjustable VERTICALE MIS Rod Inserter are shown in the Instrumentation Guide for the VERTICALE MIS System D60005.

The insertion of the rods is shown in Fig. 11 for both instruments. Prior to insertion of the rod, carry out superior-inferior alignment of the rod slots of the VERTICALE WINX Blades.

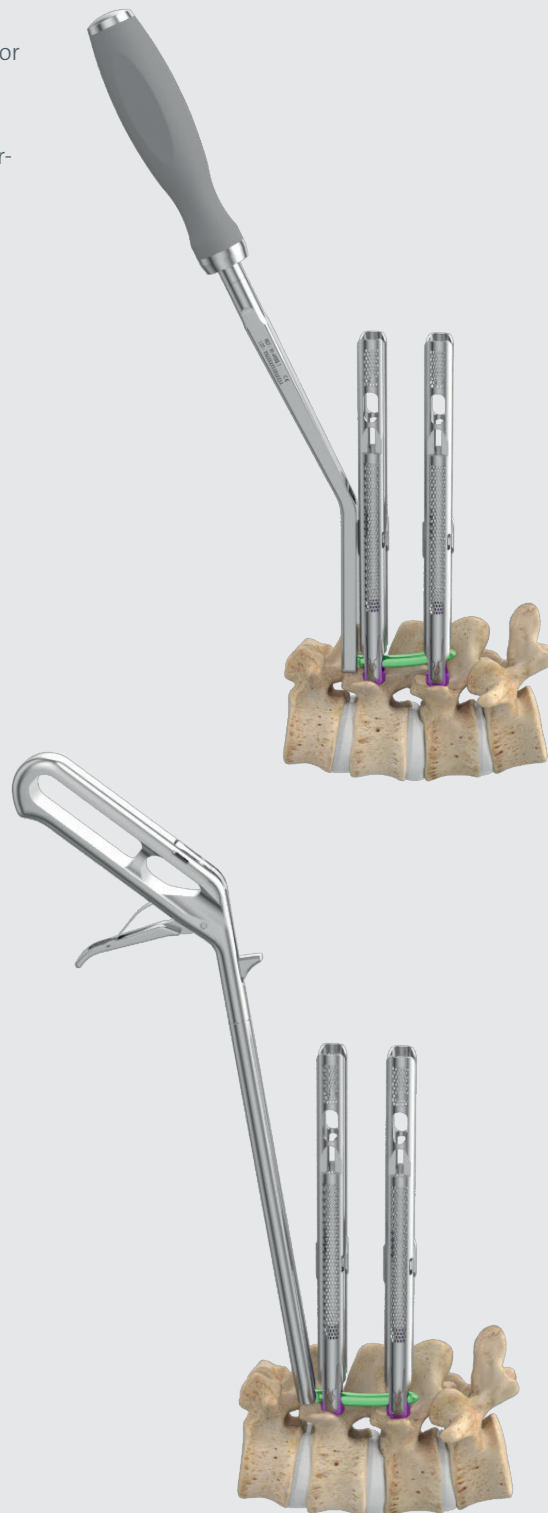

Fig. 11 Insertion of the rod with the VERTICALE MIS Rod Inserter, fix and the VERTICALE MIS Rod Inserter, adjustable

NOTE: When using a VERTICALE WINX Tower, proceed in the same way.

Positioning the rods in the screw head

VI-4470
VERTICALE WINX Tulip Adj. +
Rod Feeler



The correct placement of the rod can be verified using the VERTICALE WINX Tulip Adj. + Rod Feeler. To do so, the rod feeler is inserted via the VERTICALE WINX Blades. If a rod is located in the pedicle screw head, this is confirmed by the green marking in the inspection window. If the red marking is visible in the inspection window, then there is no rod at this location in the screw head (Fig. 12).

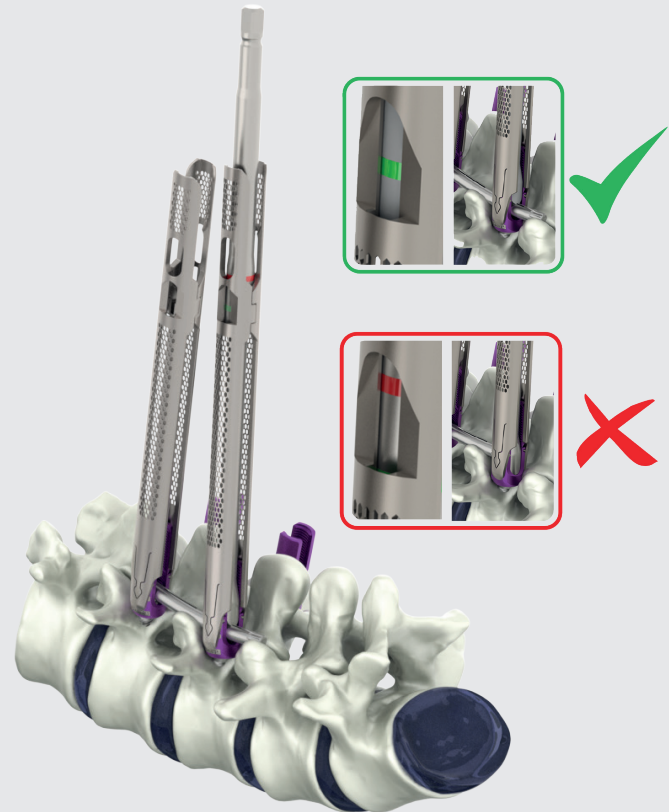

Fig. 12 Verification of the placement of the rod using the VERTICALE WINX Tulip Adj. + Rod Feeler

NOTE: It is recommended that the rod should already be inserted as deeply as possible into the pedicle screw head during insertion. It is important for lateral verification of the insertion depth of the tip of the rod to be carried out using an image intensifier.

NOTE: To enable permanent verification of the rod (rotation and positioning), it is recommended to leave the VERTICALE MIS Rod Inserter on the rod until final tightening of the set screws. In situ attachment of the rod is not possible.

Temporary fixation of the set screw

The set screw is inserted with the VERTICALE MIS Set Screw Starter according to the Instrumentation Guide for the VERTICALE MIS System D60005. Guide the VERTICALE MIS Set Screw Starter between the middle opening of the VERTICALE WINX Blades. Temporary fixation is achieved by gently turning the set screw until the rod is engaged (Fig. 13).



Fig. 13 Use the VERTICALE MIS Set Screw Starter for temporary fixation of the set screw

Compression and distraction

Relevant details can be found in the VERTICALE MIS System Instrumentation Guide D60005.

NOTE: Compression and distraction with the VERTICALE WINX Blades are only possible in combination with the VERTICALE WINX Towers to prevent the VERTICALE WINX Blades from disengaging.

Reduction maneuver

The reduction thread integrated into the pedicle screw can be used to carry out the reduction maneuver. There is a reduction travel of 18 mm available for all pedicle screws that are used together with the VERTICALE WINX Blades. Proceed according to the VERTICALE MIS System Instrumentation Guide D60005.

Final tightening

VI-4450
VERTICALE WINX Counter
Torque



VI-4170
VERTICALE MIS T25
Torque Limiter 10 Nm



The VERTICALE WINX Counter Torque is used to stabilize the rotation when tightening the set screw. To do so, the instrument is guided between the VERTICALE WINX Blades.

A laser marking on the VERTICALE WINX Counter Torque is used to visualize the end position.

The VERTICALE MIS T25 Torque Limiter 10 Nm is guided between the VERTICALE WINX Blades to its final position, where the set screw is tightened with a torque of 10 Nm. An audible click indicates that the desired torque has been applied (Fig. 14).

The same procedure must be repeated with all other set screws.

NOTE: VERTICALE WINX Towers must be removed before the final tightening as described in the section “Disengaging and removal of the WINX Tower”.

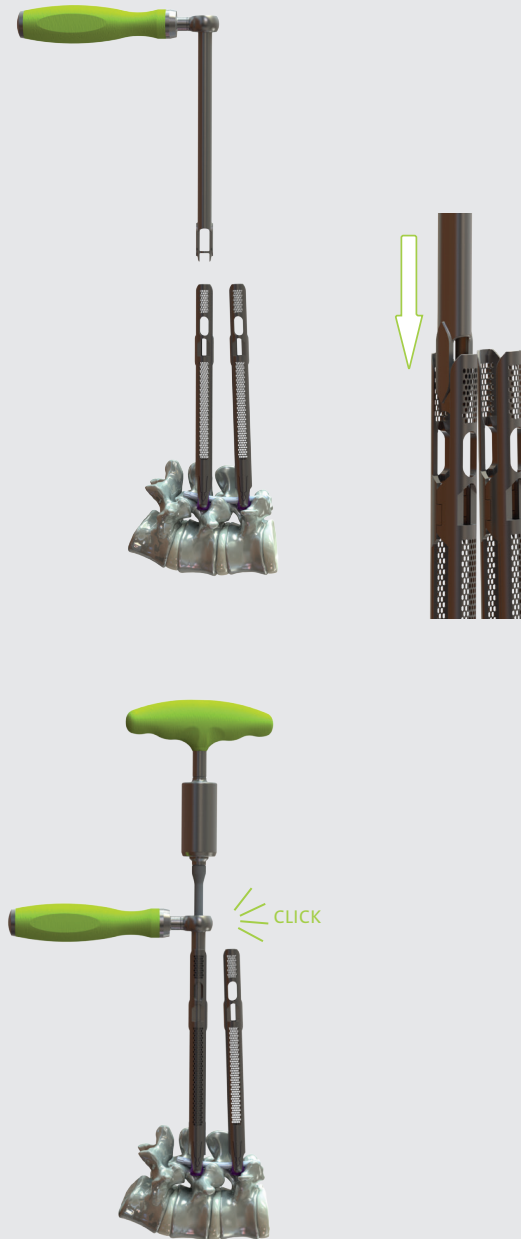

Fig. 14 Attachment of the VERTICALE WINX Counter Torque and use of the VERTICALE MIS T25 Torque Limiter 10 Nm for final tightening of the set screw.

Removal of the WINX[®] Blades

GI-3101
T-Handle



VI-4462
VERTICALE WINX Removal Tool 2.0



The VERTICALE WINX Removal Tool is guided between the VERTICALE WINX Blades. The Removal Tool has a silhouette of a "WINX Blade" laser marking which indicates the correct orientation (Fig. 15a). By pushing the instrument down until the distal pins are aligned to the WINX Blades (Fig. 15b), the WINX Blades disengage and can be removed simultaneously from the screw head.

To break off the tabs, the Removal Tool must be rotated by 90°, either way (Fig. 15c). Another indication for the final position is when the pins are aligned parallel to the rod. By rocking the instrument back and forth in the transverse plane the tabs break off (Fig. 15d).

The broken-off pedicle screw tabs remain trapped within the WINX Removal Tool and can be safely removed from the patient.

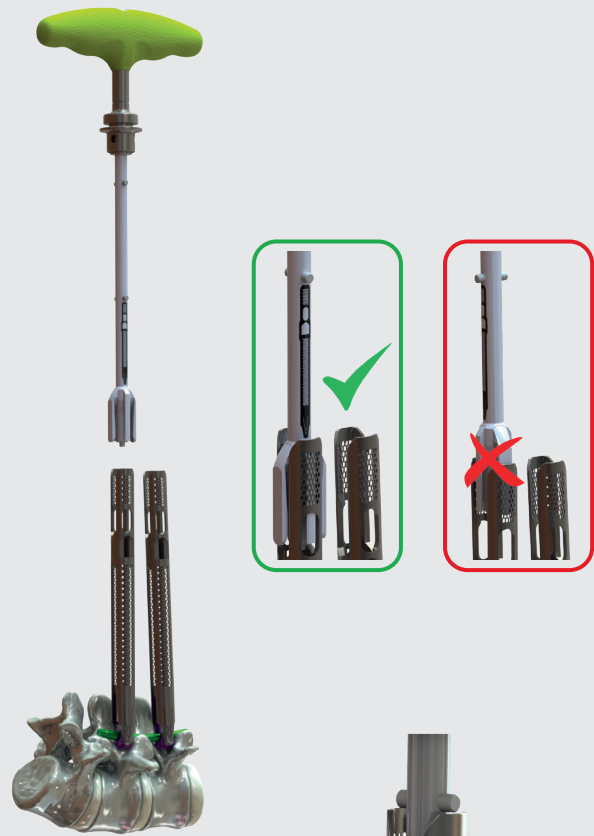

Fig. 15a



Fig. 15b



Fig. 15c, d Break off the tabs along with removing the VERTICALE WINX Blades

NOTE: If VERTICALE WINX Towers were used, remove them as described in the section "Disengaging and removal of the WINX Tower".

NOTE: Verify the final instrument result using an image intensifier with frontal and sagittal views.

NOTE: By attaching a non-ratchet T-Handle in alignment to the pins, the T-Handle can be used as another indication that the removal tool was rotated by 90° and reached its final position, parallel to the rod, to break off the tabs.

Removal of the WINX Blades and pedicle screw tabs

GI-3101
T-Handle



VI-4462
VERTICALE WINX Removal Tool 2.0



VI-4465
VERTICALE WINX Tab Capture
Tool



The WINX Tab Capture Tool is used for disengaging the tabs from the WINX Removal Tool. The WINX Removal Tool is placed on the Tab Capture Tool. By rotating the WINX Removal Tool by 90° in any direction, the tabs are released (Fig. 16).

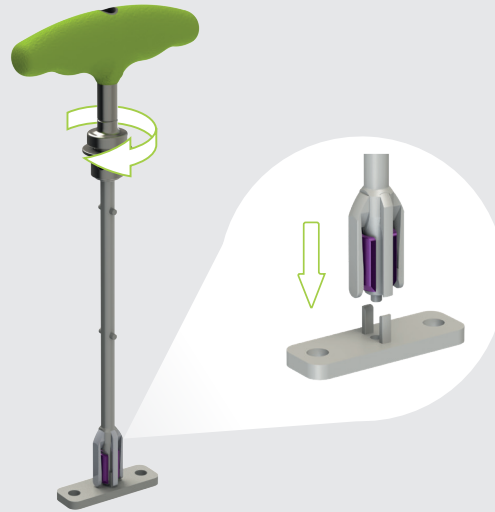

Fig. 16 Disengaging the tabs by rotating the WINX Removal Tool by 90° in any direction.

NOTE: To prevent premature wearing, the Removal Tool shall be perpendicular to the plate while rotating.

Revision of Implants

Relevant details can be found in the VERTICALE MIS System Instrumentation Guide D60005.

VERTICALE® WINX® PRODUCT INFORMATION

VERTICALE Implants by article number	PI 02–08
VERTICALE Instruments by article number	PI 09
VERTICALE General Instruments by article number	PI 10
VERTICALE Alphabetical Index	PI 11

VERTICALE Implants

Article number explanation for screws, as an example

VERTICALE Poly Screw \varnothing 4.5 \times 50 mm, reduction, cannulated and fenestrated

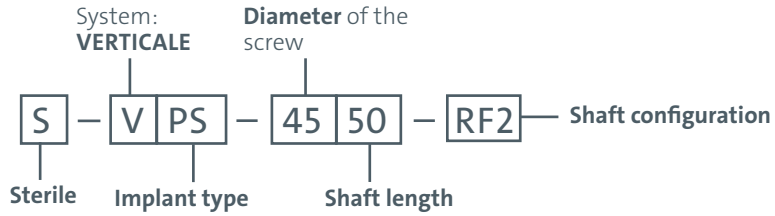

Diameter Differentiation by color coding

- \varnothing 4.5 mm
- \varnothing 5.2 mm
- \varnothing 6.2 mm
- \varnothing 7.2 mm
- \varnothing 8.2 mm
- \varnothing 9.2 mm
- \varnothing 10.2 mm

Shaft dimensions

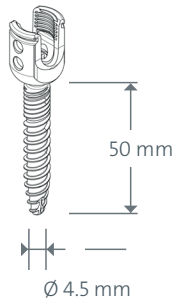

Implant type – Axial mobility

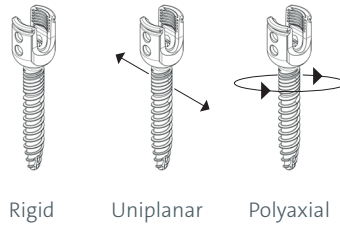

Shaft configuration – Shape

- Solid
- Cannulated
- Cannulated and fenestrated

VERTICALE® Implants

System:
VERTICALE

Implant type:
Pedicle screw

Typing:
Polyaxial, reduction,
cannulated and
fenestrated shaft

Material:
Ti6Al4V ELI

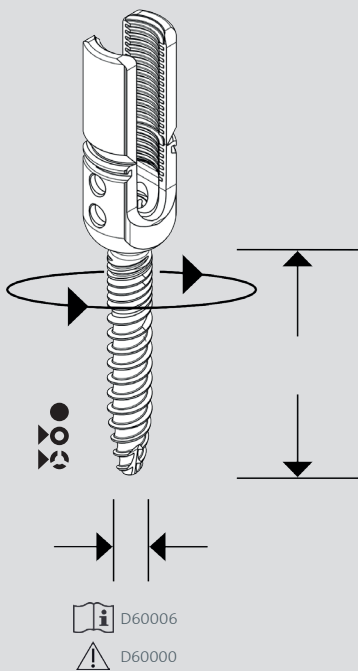

Article number	Description	Illustration
S-VPS-4525-RK2	VERTICALE Reduction Screw \varnothing 4.5 × 25 mm, can	
S-VPS-4530-RK2	VERTICALE Reduction Screw \varnothing 4.5 × 30 mm, can	
S-VPS-4535-RK2	VERTICALE Reduction Screw \varnothing 4.5 × 35 mm, can	
S-VPS-4540-RK2	VERTICALE Reduction Screw \varnothing 4.5 × 40 mm, can	
S-VPS-4545-RK2	VERTICALE Reduction Screw \varnothing 4.5 × 45 mm, can	
S-VPS-4550-RK2	VERTICALE Reduction Screw \varnothing 4.5 × 50 mm, can	
S-VPS-5225-RK2	VERTICALE Reduction Screw \varnothing 5.2 × 25 mm, can	
S-VPS-5230-RK2	VERTICALE Reduction Screw \varnothing 5.2 × 30 mm, can	
S-VPS-5235-RF2	VERTICALE Reduction Screw \varnothing 5.2 × 35 mm, can+fen	
S-VPS-5240-RF2	VERTICALE Reduction Screw \varnothing 5.2 × 40 mm, can+fen	
S-VPS-5245-RF2	VERTICALE Reduction Screw \varnothing 5.2 × 45 mm, can+fen	
S-VPS-5250-RF2	VERTICALE Reduction Screw \varnothing 5.2 × 50 mm, can+fen	
S-VPS-5255-RF2	VERTICALE Reduction Screw \varnothing 5.2 × 55 mm, can+fen	
S-VPS-5260-RF2	VERTICALE Reduction Screw \varnothing 5.2 × 60 mm, can+fen	
S-VPS-6225-RK2	VERTICALE Reduction Screw \varnothing 6.2 × 25 mm, can	
S-VPS-6230-RK2	VERTICALE Reduction Screw \varnothing 6.2 × 30 mm, can	
S-VPS-6235-RF2	VERTICALE Reduction Screw \varnothing 6.2 × 35 mm, can+fen	
S-VPS-6240-RF2	VERTICALE Reduction Screw \varnothing 6.2 × 40 mm, can+fen	
S-VPS-6245-RF2	VERTICALE Reduction Screw \varnothing 6.2 × 45 mm, can+fen	
S-VPS-6250-RF2	VERTICALE Reduction Screw \varnothing 6.2 × 50 mm, can+fen	
S-VPS-6255-RF2	VERTICALE Reduction Screw \varnothing 6.2 × 55 mm, can+fen	
S-VPS-6260-RF2	VERTICALE Reduction Screw \varnothing 6.2 × 60 mm, can+fen	
S-VPS-7225-RK2	VERTICALE Reduction Screw \varnothing 7.2 × 25 mm, can	
S-VPS-7230-RK2	VERTICALE Reduction Screw \varnothing 7.2 × 30 mm, can	
S-VPS-7235-RF2	VERTICALE Reduction Screw \varnothing 7.2 × 35 mm, can+fen	
S-VPS-7240-RF2	VERTICALE Reduction Screw \varnothing 7.2 × 40 mm, can+fen	
S-VPS-7245-RF2	VERTICALE Reduction Screw \varnothing 7.2 × 45 mm, can+fen	
S-VPS-7250-RF2	VERTICALE Reduction Screw \varnothing 7.2 × 50 mm, can+fen	
S-VPS-7255-RF2	VERTICALE Reduction Screw \varnothing 7.2 × 55 mm, can+fen	
S-VPS-7260-RF2	VERTICALE Reduction Screw \varnothing 7.2 × 60 mm, can+fen	
S-VPS-7270-RF2	VERTICALE Reduction Screw \varnothing 7.2 × 70 mm, can+fen	
S-VPS-7280-RF2	VERTICALE Reduction Screw \varnothing 7.2 × 80 mm, can+fen	

VERTICALE® Implants

Article number	Description	Illustration
S-VFS-4525-RK2	VERTICALE Mono Reduction Screw Ø 4.5 × 25 mm, can	
S-VFS-4530-RK2	VERTICALE Mono Reduction Screw Ø 4.5 × 30 mm, can	
S-VFS-4535-RK2	VERTICALE Mono Reduction Screw Ø 4.5 × 35 mm, can	
S-VFS-4540-RK2	VERTICALE Mono Reduction Screw Ø 4.5 × 40 mm, can	
S-VFS-4545-RK2	VERTICALE Mono Reduction Screw Ø 4.5 × 45 mm, can	
S-VFS-4550-RK2	VERTICALE Mono Reduction Screw Ø 4.5 × 50 mm, can	
S-VFS-5225-RK2	VERTICALE Mono Reduction Screw Ø 5.2 × 25 mm, can	
S-VFS-5230-RK2	VERTICALE Mono Reduction Screw Ø 5.2 × 30 mm, can	
S-VFS-5235-RF2	VERTICALE Mono Reduction Screw Ø 5.2 × 35 mm, can+fen	
S-VFS-5240-RF2	VERTICALE Mono Reduction Screw Ø 5.2 × 40 mm, can+fen	
S-VFS-5245-RF2	VERTICALE Mono Reduction Screw Ø 5.2 × 45 mm, can+fen	
S-VFS-5250-RF2	VERTICALE Mono Reduction Screw Ø 5.2 × 50 mm, can+fen	
S-VFS-5255-RF2	VERTICALE Mono Reduction Screw Ø 5.2 × 55 mm, can+fen	
S-VFS-5260-RF2	VERTICALE Mono Reduction Screw Ø 5.2 × 60 mm, can+fen	
S-VFS-6225-RK2	VERTICALE Mono Reduction Screw Ø 6.2 × 25 mm, can	
S-VFS-6230-RK2	VERTICALE Mono Reduction Screw Ø 6.2 × 30 mm, can	
S-VFS-6235-RF2	VERTICALE Mono Reduction Screw Ø 6.2 × 35 mm, can+fen	
S-VFS-6240-RF2	VERTICALE Mono Reduction Screw Ø 6.2 × 40 mm, can+fen	
S-VFS-6245-RF2	VERTICALE Mono Reduction Screw Ø 6.2 × 45 mm, can+fen	
S-VFS-6250-RF2	VERTICALE Mono Reduction Screw Ø 6.2 × 50 mm, can+fen	
S-VFS-6255-RF2	VERTICALE Mono Reduction Screw Ø 6.2 × 55 mm, can+fen	
S-VFS-6260-RF2	VERTICALE Mono Reduction Screw Ø 6.2 × 60 mm, can+fen	
S-VFS-7225-RK2	VERTICALE Mono Reduction Screw Ø 7.2 × 25 mm, can	
S-VFS-7230-RK2	VERTICALE Mono Reduction Screw Ø 7.2 × 30 mm, can	
S-VFS-7235-RF2	VERTICALE Mono Reduction Screw Ø 7.2 × 35 mm, can+fen	
S-VFS-7240-RF2	VERTICALE Mono Reduction Screw Ø 7.2 × 40 mm, can+fen	
S-VFS-7245-RF2	VERTICALE Mono Reduction Screw Ø 7.2 × 45 mm, can+fen	
S-VFS-7250-RF2	VERTICALE Mono Reduction Screw Ø 7.2 × 50 mm, can+fen	
S-VFS-7255-RF2	VERTICALE Mono Reduction Screw Ø 7.2 × 55 mm, can+fen	
S-VFS-7260-RF2	VERTICALE Mono Reduction Screw Ø 7.2 × 60 mm, can+fen	
S-VFS-7270-RF2	VERTICALE Mono Reduction Screw Ø 7.2 × 70 mm, can+fen	
S-VFS-7280-RF2	VERTICALE Mono Reduction Screw Ø 7.2 × 80 mm, can+fen	

System:
VERTICALE

Implant type:
Pedicle screw

Typing:
Monoaxial, reduction,
cannulated and
fenestrated shaft

Material:
Ti6Al4V ELI

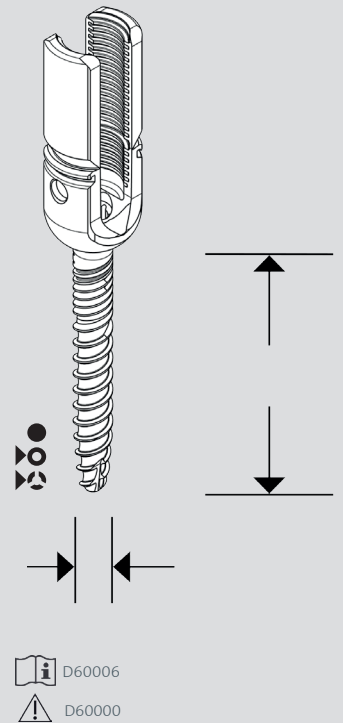

VERTICALE® Implants

System:
VERTICALE

Implant type:
Pedicle screw

Typing:
Monoaxial, reduction,
cannulated and
fenestrated shaft

Material:
Ti6Al4V ELI

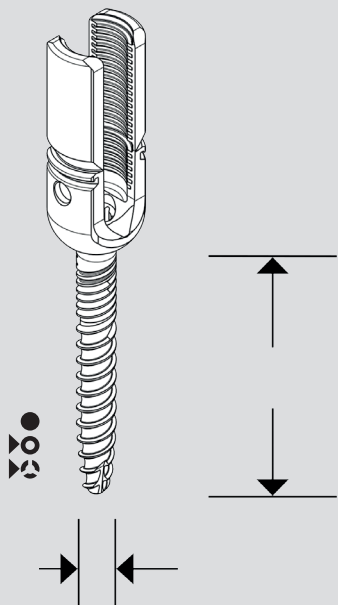

 D60006

 D60000

Article number	Description	Illustration
S-VFS-8225-RK2	VERTICALE Mono Reduction Screw \varnothing 8.2 × 25 mm, can	
S-VFS-8230-RK2	VERTICALE Mono Reduction Screw \varnothing 8.2 × 30 mm, can	
S-VFS-8235-RF2	VERTICALE Mono Reduction Screw \varnothing 8.2 × 35 mm, can+fen	
S-VFS-8240-RF2	VERTICALE Mono Reduction Screw \varnothing 8.2 × 40 mm, can+fen	
S-VFS-8245-RF2	VERTICALE Mono Reduction Screw \varnothing 8.2 × 45 mm, can+fen	
S-VFS-8250-RF2	VERTICALE Mono Reduction Screw \varnothing 8.2 × 50 mm, can+fen	
S-VFS-8255-RF2	VERTICALE Mono Reduction Screw \varnothing 8.2 × 55 mm, can+fen	
S-VFS-8260-RF2	VERTICALE Mono Reduction Screw \varnothing 8.2 × 60 mm, can+fen	
VFS-8270-RF2	VERTICALE Mono Reduction Screw \varnothing 8.2 × 70 mm, can+fen	
VFS-8280-RF2	VERTICALE Mono Reduction Screw \varnothing 8.2 × 80 mm, can+fen	
VFS-8290-RF2	VERTICALE Mono Reduction Screw \varnothing 8.2 × 90 mm, can+fen	
VFS-8210-RF2	VERTICALE Mono Reduction Screw \varnothing 8.2 × 100 mm, can+fen	
S-VFS-9225-RK2	VERTICALE Mono Reduction Screw \varnothing 9.2 × 25 mm, can	
S-VFS-9230-RK2	VERTICALE Mono Reduction Screw \varnothing 9.2 × 30 mm, can	
S-VFS-9235-RF2	VERTICALE Mono Reduction Screw \varnothing 9.2 × 35 mm, can+fen	
S-VFS-9240-RF2	VERTICALE Mono Reduction Screw \varnothing 9.2 × 40 mm, can+fen	
S-VFS-9245-RF2	VERTICALE Mono Reduction Screw \varnothing 9.2 × 45 mm, can+fen	
S-VFS-9250-RF2	VERTICALE Mono Reduction Screw \varnothing 9.2 × 50 mm, can+fen	
S-VFS-9255-RF2	VERTICALE Mono Reduction Screw \varnothing 9.2 × 55 mm, can+fen	
S-VFS-9260-RF2	VERTICALE Mono Reduction Screw \varnothing 9.2 × 60 mm, can+fen	
S-VFS-9270-RF2	VERTICALE Mono Reduction Screw \varnothing 9.2 × 70 mm, can+fen	
S-VFS-9280-RF2	VERTICALE Mono Reduction Screw \varnothing 9.2 × 80 mm, can+fen	
S-VFS-9290-RF2	VERTICALE Mono Reduction Screw \varnothing 9.2 × 90 mm, can+fen	
S-VFS-9210-RF2	VERTICALE Mono Reduction Screw \varnothing 9.2 × 100 mm, can+fen	
S-VFS-0225-RK2	VERTICALE Mono Reduction Screw \varnothing 10.2 × 25 mm, can	
S-VFS-0230-RK2	VERTICALE Mono Reduction Screw \varnothing 10.2 × 30 mm, can	
S-VFS-0235-RF2	VERTICALE Mono Reduction Screw \varnothing 10.2 × 35 mm, can+fen	
S-VFS-0240-RF2	VERTICALE Mono Reduction Screw \varnothing 10.2 × 40 mm, can+fen	
S-VFS-0245-RF2	VERTICALE Mono Reduction Screw \varnothing 10.2 × 45 mm, can+fen	
S-VFS-0250-RF2	VERTICALE Mono Reduction Screw \varnothing 10.2 × 50 mm, can+fen	
S-VFS-0255-RF2	VERTICALE Mono Reduction Screw \varnothing 10.2 × 55 mm, can+fen	
S-VFS-0260-RF2	VERTICALE Mono Reduction Screw \varnothing 10.2 × 60 mm, can+fen	
S-VFS-0270-RF2	VERTICALE Mono Reduction Screw \varnothing 10.2 × 70 mm, can+fen	
S-VFS-0280-RF2	VERTICALE Mono Reduction Screw \varnothing 10.2 × 80 mm, can+fen	
S-VFS-0290-RF2	VERTICALE Mono Reduction Screw \varnothing 10.2 × 90 mm, can+fen	
S-VFS-0210-RF2	VERTICALE Mono Reduction Screw \varnothing 10.2 × 100 mm, can+fen	

VERTICALE® Implants

Article number	Description	Illustration
S-VUS-4525-RK2	VERTICALE Uni Reduction Screw $\varnothing 4.5 \times 25$ mm, can	
S-VUS-4530-RK2	VERTICALE Uni Reduction Screw $\varnothing 4.5 \times 30$ mm, can	
S-VUS-4535-RK2	VERTICALE Uni Reduction Screw $\varnothing 4.5 \times 35$ mm, can	
S-VUS-4540-RK2	VERTICALE Uni Reduction Screw $\varnothing 4.5 \times 40$ mm, can	
S-VUS-4545-RK2	VERTICALE Uni Reduction Screw $\varnothing 4.5 \times 45$ mm, can	
S-VUS-4550-RK2	VERTICALE Uni Reduction Screw $\varnothing 4.5 \times 50$ mm, can	
S-VUS-5225-RK2	VERTICALE Uni Reduction Screw $\varnothing 5.2 \times 25$ mm, can	
S-VUS-5230-RK2	VERTICALE Uni Reduction Screw $\varnothing 5.2 \times 30$ mm, can	
S-VUS-5235-RF2	VERTICALE Uni Reduction Screw $\varnothing 5.2 \times 35$ mm, can+fen	
S-VUS-5240-RF2	VERTICALE Uni Reduction Screw $\varnothing 5.2 \times 40$ mm, can+fen	
S-VUS-5245-RF2	VERTICALE Uni Reduction Screw $\varnothing 5.2 \times 45$ mm, can+fen	
S-VUS-5250-RF2	VERTICALE Uni Reduction Screw $\varnothing 5.2 \times 50$ mm, can+fen	
S-VUS-5255-RF2	VERTICALE Uni Reduction Screw $\varnothing 5.2 \times 55$ mm, can+fen	
S-VUS-5260-RF2	VERTICALE Uni Reduction Screw $\varnothing 5.2 \times 60$ mm, can+fen	
S-VUS-6225-RK2	VERTICALE Uni Reduction Screw $\varnothing 6.2 \times 25$ mm, can	
S-VUS-6230-RK2	VERTICALE Uni Reduction Screw $\varnothing 6.2 \times 30$ mm, can	
S-VUS-6235-RF2	VERTICALE Uni Reduction Screw $\varnothing 6.2 \times 35$ mm, can+fen	
S-VUS-6240-RF2	VERTICALE Uni Reduction Screw $\varnothing 6.2 \times 40$ mm, can+fen	
S-VUS-6245-RF2	VERTICALE Uni Reduction Screw $\varnothing 6.2 \times 45$ mm, can+fen	
S-VUS-6250-RF2	VERTICALE Uni Reduction Screw $\varnothing 6.2 \times 50$ mm, can+fen	
S-VUS-6255-RF2	VERTICALE Uni Reduction Screw $\varnothing 6.2 \times 55$ mm, can+fen	
S-VUS-6260-RF2	VERTICALE Uni Reduction Screw $\varnothing 6.2 \times 60$ mm, can+fen	
S-VUS-7225-RK2	VERTICALE Uni Reduction Screw $\varnothing 7.2 \times 25$ mm, can	
S-VUS-7230-RK2	VERTICALE Uni Reduction Screw $\varnothing 7.2 \times 30$ mm, can	
S-VUS-7235-RF2	VERTICALE Uni Reduction Screw $\varnothing 7.2 \times 35$ mm, can+fen	
S-VUS-7240-RF2	VERTICALE Uni Reduction Screw $\varnothing 7.2 \times 40$ mm, can+fen	
S-VUS-7245-RF2	VERTICALE Uni Reduction Screw $\varnothing 7.2 \times 45$ mm, can+fen	
S-VUS-7250-RF2	VERTICALE Uni Reduction Screw $\varnothing 7.2 \times 50$ mm, can+fen	
S-VUS-7255-RF2	VERTICALE Uni Reduction Screw $\varnothing 7.2 \times 55$ mm, can+fen	
S-VUS-7260-RF2	VERTICALE Uni Reduction Screw $\varnothing 7.2 \times 60$ mm, can+fen	
S-VUS-7270-RF2	VERTICALE Uni Reduction Screw $\varnothing 7.2 \times 70$ mm, can+fen	
S-VUS-7280-RF2	VERTICALE Uni Reduction Screw $\varnothing 7.2 \times 80$ mm, can+fen	

System:
VERTICALE

Implant type:
Pedicle screw

Typing:
Uniplanar, reduction,
cannulated and
fenestrated shaft

Material:
Ti6Al4V ELI

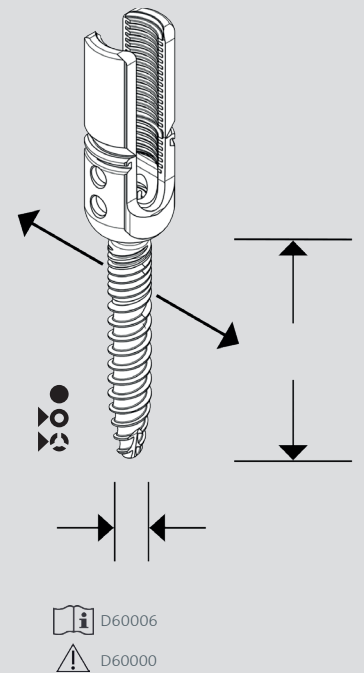

VERTICALE® Implants

System:
VERTICALE

Implant type:
Pedicle screw

Typing:
Polyaxial ST (Self tapping),
reduction, cannulated and
fenestrated shaft

Material:
Ti6Al4V ELI

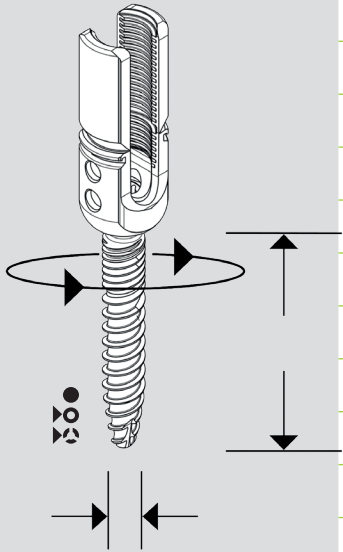

Article number	Description	Illustration
S-VPS-8225-RK3	VERTICALE Reduction Screw ST Ø 8.2 × 25 mm, can	
S-VPS-8230-RK3	VERTICALE Reduction Screw ST Ø 8.2 × 30 mm, can	
S-VPS-8235-RF3	VERTICALE Reduction Screw ST Ø 8.2 × 35 mm, can+fen	
S-VPS-8240-RF3	VERTICALE Reduction Screw ST Ø 8.2 × 40 mm, can+fen	
S-VPS-8245-RF3	VERTICALE Reduction Screw ST Ø 8.2 × 45 mm, can+fen	
S-VPS-8250-RF3	VERTICALE Reduction Screw ST Ø 8.2 × 50 mm, can+fen	
S-VPS-8255-RF3	VERTICALE Reduction Screw ST Ø 8.2 × 55 mm, can+fen	
S-VPS-8260-RF3	VERTICALE Reduction Screw ST Ø 8.2 × 60 mm, can+fen	
S-VPS-9225-RK3	VERTICALE Reduction Screw ST Ø 9.2 × 25 mm, can	
S-VPS-9230-RK3	VERTICALE Reduction Screw ST Ø 9.2 × 30 mm, can	
S-VPS-9235-RF3	VERTICALE Reduction Screw ST Ø 9.2 × 35 mm, can+fen	
S-VPS-9240-RF3	VERTICALE Reduction Screw ST Ø 9.2 × 40 mm, can+fen	
S-VPS-9245-RF3	VERTICALE Reduction Screw ST Ø 9.2 × 45 mm, can+fen	
S-VPS-9250-RF3	VERTICALE Reduction Screw ST Ø 9.2 × 50 mm, can+fen	
S-VPS-9255-RF3	VERTICALE Reduction Screw ST Ø 9.2 × 55 mm, can+fen	
S-VPS-9260-RF3	VERTICALE Reduction Screw ST Ø 9.2 × 60 mm, can+fen	
S-VPS-0225-RK3	VERTICALE Reduction Screw ST Ø 10.2 × 25 mm, can	
S-VPS-0230-RK3	VERTICALE Reduction Screw ST Ø 10.2 × 30 mm, can	
S-VPS-0235-RF3	VERTICALE Reduction Screw ST Ø 10.2 × 35 mm, can+fen	
S-VPS-0240-RF3	VERTICALE Reduction Screw ST Ø 10.2 × 40 mm, can+fen	
S-VPS-0245-RF3	VERTICALE Reduction Screw ST Ø 10.2 × 45 mm, can+fen	
S-VPS-0250-RF3	VERTICALE Reduction Screw ST Ø 10.2 × 50 mm, can+fen	
S-VPS-0255-RF3	VERTICALE Reduction Screw ST Ø 10.2 × 55 mm, can+fen	
S-VPS-0260-RF3	VERTICALE Reduction Screw ST Ø 10.2 × 60 mm, can+fen	

VERTICALE® Implants

Article number	Description	Illustration
S-VIS-8270-RF2	VERTICALE Iliac Reduction Screw Ø 8.2 × 70 mm, can+fen	
S-VIS-8280-RF2	VERTICALE Iliac Reduction Screw Ø 8.2 × 80 mm, can+fen	
S-VIS-8290-RF2	VERTICALE Iliac Reduction Screw Ø 8.2 × 90 mm, can+fen	
S-VIS-8210-RF2	VERTICALE Iliac Reduction Screw Ø 8.2 × 100 mm, can+fen	
S-VIS-9270-RF2	VERTICALE Iliac Reduction Screw Ø 9.2 × 70 mm, can+fen	
S-VIS-9280-RF2	VERTICALE Iliac Reduction Screw Ø 9.2 × 80 mm, can+fen	
S-VIS-9290-RF2	VERTICALE Iliac Reduction Screw Ø 9.2 × 90 mm, can+fen	
S-VIS-9210-RF2	VERTICALE Iliac Reduction Screw Ø 9.2 × 100 mm, can+fen	
S-VIS-0270-RF2	VERTICALE Iliac Reduction Screw Ø 10.2 × 70 mm, can+fen	
S-VIS-0280-RF2	VERTICALE Iliac Reduction Screw Ø 10.2 × 80 mm, can+fen	
S-VIS-0290-RF2	VERTICALE Iliac Reduction Screw Ø 10.2 × 90 mm, can+fen	
S-VIS-0210-RF2	VERTICALE Iliac Reduction Screw Ø 10.2 × 100 mm, can+fen	
S-VMS-2025	VERTICALE Set Screw 1S Torx 25	

System:
VERTICALE

Implant type:
Iliac screw

Typing:
Ilium reduction,
cannulated and
fenestrated shaft

Material:
Ti6Al4V ELI

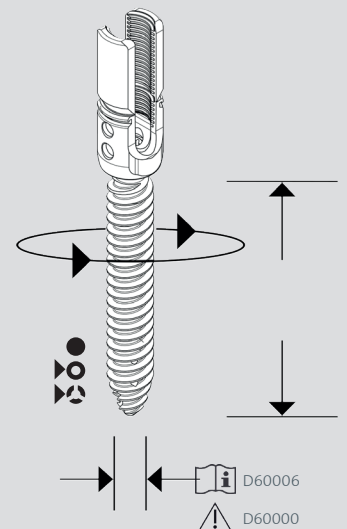

Article number	Description	Illustration
S-VST-4040-T	VERTICALE MIS Rod curved Ø 5.5 / 40 mm Ti	
S-VST-4045-T	VERTICALE MIS Rod curved Ø 5.5 / 45 mm Ti	
S-VST-4050-T	VERTICALE MIS Rod curved Ø 5.5 / 50 mm Ti	
S-VST-4055-T	VERTICALE MIS Rod curved Ø 5.5 / 55 mm Ti	
S-VST-4065-T	VERTICALE MIS Rod curved Ø 5.5 / 65 mm Ti	
S-VST-4075-T	VERTICALE MIS Rod curved Ø 5.5 / 75 mm Ti	
S-VST-4085-T	VERTICALE MIS Rod curved Ø 5.5 / 85 mm Ti	
S-VST-4095-T	VERTICALE MIS Rod curved Ø 5.5 / 95 mm Ti	
S-VST-4105-T	VERTICALE MIS Rod curved Ø 5.5 / 105 mm Ti	
S-VST-4115-T	VERTICALE MIS Rod curved Ø 5.5 / 115 mm Ti	
S-VST-4125-T	VERTICALE MIS Rod curved Ø 5.5 / 125 mm Ti	
S-VST-4135-T	VERTICALE MIS Rod curved Ø 5.5 / 135 mm Ti	

System:
VERTICALE

Implant type:
Rod

Typing:
curved

Material:
Ti6Al4V ELI

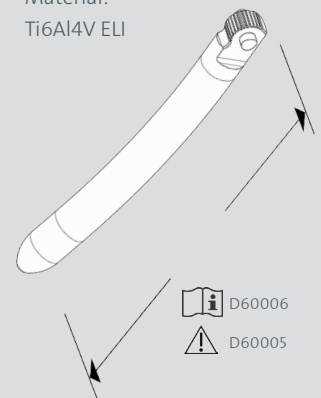

VERTICALE® Implants

System:
VERTICALE

Implant type:
Rod

Typing:
straight

Material:
Ti6Al4V ELI

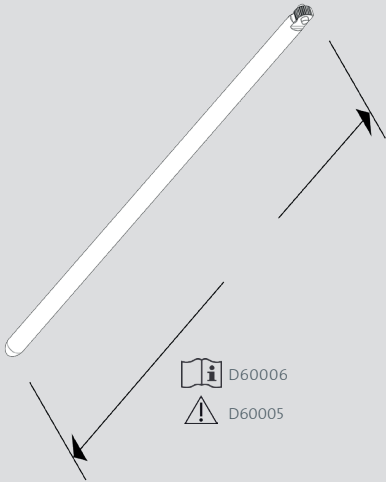

Article number	Description	Illustration
S-VST-4080-T	VERTICALE MIS Rod straight Ø 5.5 / 80 mm Ti	
S-VST-4090-T	VERTICALE MIS Rod straight Ø 5.5 / 90 mm Ti	
S-VST-4100-T	VERTICALE MIS Rod straight Ø 5.5 / 100 mm Ti	
S-VST-4110-T	VERTICALE MIS Rod straight Ø 5.5 / 110 mm Ti	
S-VST-4120-T	VERTICALE MIS Rod straight Ø 5.5 / 120 mm Ti	
S-VST-4130-T	VERTICALE MIS Rod straight Ø 5.5 / 130 mm Ti	
S-VST-4140-T	VERTICALE MIS Rod straight Ø 5.5 / 140 mm Ti	
S-VST-4150-T	VERTICALE MIS Rod straight Ø 5.5 / 150 mm Ti	
S-VST-4170-T	VERTICALE MIS Rod straight Ø 5.5 / 170 mm Ti	
S-VST-4200-T	VERTICALE MIS Rod straight Ø 5.5 / 200 mm Ti	
S-VST-4210-T	VERTICALE MIS Rod straight Ø 5.5 / 210 mm Ti	
S-VST-4220-T	VERTICALE MIS Rod straight Ø 5.5 / 220 mm Ti	
S-VST-4230-T	VERTICALE MIS Rod straight Ø 5.5 / 230 mm Ti	
S-VST-4240-T	VERTICALE MIS Rod straight Ø 5.5 / 240 mm Ti	
S-VST-4250-T	VERTICALE MIS Rod straight Ø 5.5 / 250 mm Ti	
S-VST-4260-T	VERTICALE MIS Rod straight Ø 5.5 / 260 mm Ti	
S-VST-4270-T	VERTICALE MIS Rod straight Ø 5.5 / 270 mm Ti	
S-VST-4280-T	VERTICALE MIS Rod straight Ø 5.5 / 280 mm Ti	
S-VST-4300-T	VERTICALE MIS Rod straight Ø 5.5 / 300 mm Ti	
S-VST-4330-T	VERTICALE MIS Rod straight Ø 5.5 / 330 mm Ti	
S-VST-4370-T	VERTICALE MIS Rod straight Ø 5.5 / 370 mm Ti	
S-VST-4400-T	VERTICALE MIS Rod straight Ø 5.5 / 400 mm Ti	
S-VST-4430-T	VERTICALE MIS Rod straight Ø 5.5 / 430 mm Ti	
S-VST-4470-T	VERTICALE MIS Rod straight Ø 5.5 / 470 mm Ti	

System:
VERTICALE

Implant type:
Rod

Typing:
straight

Material:
CoCr

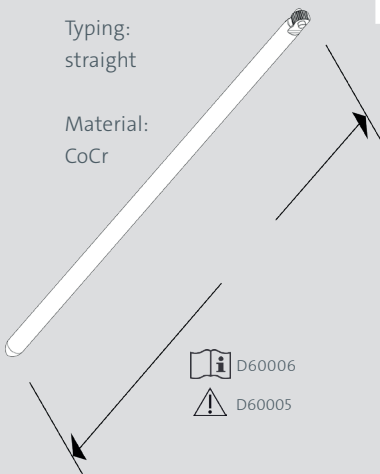

Article number	Description	Illustration
S-VST-4200-C	VERTICALE MIS Rod straight Ø 5.5 / 200 mm CoCr	
S-VST-4300-C	VERTICALE MIS Rod straight Ø 5.5 / 300 mm CoCr	
S-VST-4470-C	VERTICALE MIS Rod straight Ø 5.5 / 470 mm CoCr	

Article number	Description	Illustration	Page
VI-1060	VERTICALE Guide Wire with trocar tip		13
VI-1070	VERTICALE Guide Wire with round tip		13
VI-4024	VERTICALE MIS Dilator 4 (20 mm)		13
VI-4060	VERTICALE MIS Rod Gauge		15
VI-4061	VERTICALE MIS Rod Length Verifier		15
VI-4120	VERTICALE MIS Set Screw Starter		18
VI-4170	VERTICALE MIS T25 Torque Limiter 10 Nm		19
VI-4412	VERTICALE WINX Blade 2.0		9
VI-4422	VERTICALE WINX Tower 2.0		10, 11
VI-4440	VERTICALE WINX Screwdriver		12
VI-4450	VERTICALE WINX Counter Torque		19
VI-4462	VERTICALE WINX Removal Tool 2.0		20, 21
VI-4465	VERTICALE WINX Tab Capture Tool		21
VI-4470	VERTICALE WINX Tulip Adj. + Rod Feeler		14, 17

VERTICALE® General Instruments

Article number	Description	Illustration	Page
GI-3111	Ratchet T-Handle, cannulated		12, 14
GI-3101	T-Handle, cannulated		12, 14
GI-3211	Ratchet Handle, cannulated		12, 14
GI-3201	Handle, cannulated		12, 14
GI-3311	Ratchet Palm Handle, cannulated		12, 14
GI-3301	Palm Handle, cannulated		12, 14
GI-2111	Ratchet T-Handle, short		12, 14
GI-2101	T-Handle, short		12, 14
GI-2311	Ratchet Palm Handle, short		12, 14
GI-2301	Palm Handle, short		12, 14

VERTICALE® Alphabetical Index

A-Z	Description	Article number	Page
B	VERTICALE WINX Blade 2.0	VI-4412	9
	VERTICALE WINX Counter Torque	VI-4450	19
D	VERTICALE MIS Dilator 4 (20 mm)	VI-4024	13
G	VERTICALE Guide Wire with trocar tip	VI-1060	13
R	Ratchet T-Handle, cannulated	GI-3111	12, 14
	VERTICALE WINX Removal Tool 2.0	VI-4462	20, 21
	VERTICALE MIS Rod Gauge	VI-4060	15
	VERTICALE MIS Rod Length Verifier	VI-4061	15
S	VERTICALE WINX Screwdriver	VI-4440	12
	VERTICALE MIS Set Screw Starter	VI-4120	18
T	VERTICALE WINX Tab Capture Tool	VI-4465	21
	VERTICALE MIS T25 Torque Limiter 10 Nm	VI-4170	19
	VERTICALE WINX Tower 2.0	VI-4422	10, 11
	VERTICALE WINX Tulip Adj. + Rod Feeler	VI-4470	14, 17

Notes

A series of horizontal dotted lines for writing notes, spanning the width of the page.



 **Silony Medical GmbH**
Leinfelder Straße 60
70771 Leinfelden-Echterdingen
Germany
Tel +49 711 78 25 25 0
Fax +49 711 78 25 25 11
www.silonyspine.com

 e labeling.silony-medical.com/contact

This information is only intended for the USA and its territories.

D60055.e.EN 22.01.2024

