

VERTICALE[®] MULTILOCKING

INSTRUMENTATION GUIDE



MADE IN GERMANY

TABLE OF CONTENTS

Preface	3
Indication / contraindication	4
VERTICALE® MultiLocking – INSTRUMENTATION	5
Selection of pedicle screws	6
Instrumentation with VERTICALE® MultiLocking Short-Head Screws	7
Screw attachment with the locking and reduction tower	8
Temporary fixation of the polyaxiality	9
Preparing the pedicle screwdriver	10
Pedicle screw placement	10
Selecting and inserting the rods	11
Temporary fixation of the set screw	12
Reduction with the locking and reduction tower	13
Final tightening using the counter torque	14
Reconnecting the locking and reduction tower	15
Corrective maneuver with the fracture correction frame	16
Preparing the fracture frame	17
Parallel distraction/compression	18
Lordosis/kyphosis	19
Removing the fracture frame	20
Instrumentation with VERTICALE® MultiLocking Long-Head Screws	21
Inserting the screw	22
Temporary fixation of the polyaxiality	23
Selecting and inserting the rods	24
Temporary fixation of the set screw	25
Final tightening using the counter torque	26
Removing the tabs	26
PRODUCT INFORMATION	PI 01
VERTICALE® MultiLocking Implants	PI 02
VERTICALE® MultiLocking Instruments (supplement to VERTICALE® Instruments)	PI 06
VERTICALE® Alphabetical Index	PI 08

PREFACE

VERTICALE[®] – MULTILOCKING FULL CORRECTION CONTROL

VERTICALE[®] is a dorsal screw-rod fixation system for stabilizing the thoracic and lumbar spine. The VERTICALE MultiLocking System is an extension of the dorsal screw-rod system and offers additional corrective options. The unique technology of the MultiLocking screw enables the polyaxiality of the MultiLocking screw to be locked or released. This option means that the MultiLocking screw can function at any time as a monoaxial screw. Using this system lordosis or kyphosis can be actively adjusted and rotation maneuvers or even parallel distraction or compression can be performed. The corrective maneuvers can be performed without rods inserted and enable a broad range of uses including the treatment of complex deformities or fracture of the spine.

Like all other implants and instruments developed by Silony Medical, VERTICALE MultiLocking is a living system. Whether instrument or implant—we are constantly working to expand and improve our systems in order to optimally meet the needs of patients, physicians, and hospital nursing staff.

To meet the needs of surgeons in the best possible manner we are collaborating in every product development project with a group of renowned surgeons, the Medical Advisory Board (MAB). Based on the initial concept of product design, the MAB is involved throughout the entire product development process and provides our team of engineers with expert advice.

To ensure that we fulfill our claim to be "clinically driven" we also appoint, in addition to the MAB, a Process Advisory Board (PAB) for every development project. The PAB is made up of experienced and competent medical professionals, especially nursing staff and sterilization experts. They not only play a key role in product development but also ensure that our products, services, and solutions meet all requirements both at the operating table and throughout everyday clinical routine.

Our top priority is the health and safety of your patients. Silony Medical supports you in your capacity as a physician and clinician with our products and solutions.

We would like to thank all the MAB surgeons and PAB clinicians who were involved in this development.

NOTE: The following guide is intended to familiarize you with the surgical procedure and use of the VERTICALE MultiLocking Screws and the associated instruments. This instrumentation guide supplements the guide for the VERTICALE Screw-Rod System. Instruments from Silony Medical are processed, serviced, and cared for in accordance with the information given in the instructions for use. Please read this guide and the instructions for use accompanying the implants carefully before using the implant, and also pay particular attention to the information appended to this guide.

This guide does not replace briefing by a surgeon experienced in the instrumentation used in spinal surgery.

We would be happy to assist you in finding a hospital that provides an opportunity to observe surgical procedures.

Indications

The VERTICALE System is indicated for use in the thoracic and lumbar spine as well as for iliosacral fixation procedures (T1–S2 / ilium). This includes all kinds of thoracic and lumbar instabilities that require comprehensive posterior pedicle screw fixation:

- Degenerative disc diseases
- Spondylolisthesis of all etiologies
- Stenosis
- Deformities such as scoliosis and kyphosis
- Fractures
- Spondylitis
- Tumors
- Revisions
- Pseudarthrosis

Contraindications

Under certain circumstances, implantation is contraindicated or associated with substantial risks, even though there may be an indication. These include in particular:

- Anticipated or documented allergy or intolerance to the materials used (e.g. titanium or cobalt chromium)
- Any case in which the chosen implants would be too large or too small to achieve a successful result
- Any patient for whom the use of the implant would conflict with anatomical structures
- Missing bony structures that make solid anchoring of the implant impossible (e.g. in the case of fractures, tumors or osteoporosis).

NOTE: Anterior, interbody support in the form of an intervertebral implant device, such as a ROCCIA Cage, is recommended for treating instabilities of the anterior spine and is used at the discretion of the operating surgeon and in accordance with the respective indication.

NOTE: Please also note the Instructions for Use provided with each product. They may include additional advice that leads to exclusion of the implant procedure.

VERTICALE® MULTILOCKING INSTRUMENTATION

The following section describes only the specific steps that are required when using the MultiLocking screws. For a general instrumentation guide for a dorsal VERTICALE standard instrumentation that forms the basis of all subsequent work steps for both open and minimally invasive approaches, we ask that you study the instrumentation guide for the VERTICALE® OPEN Screw-Rod System (D30000) and the instrumentation guide for the VERTICALE® MIS Screw-Rod System (D30049).

Multisegmental instrumentations are also explained in this guide.

IMPORTANT NOTE:

The preceding guide steps for opening, preparing the pedicle, and determining the screw length can be found, depending on the approach, in the VERTICALE OPEN or MIS Standard Instrumentation Guide.

Selection of pedicle screws

For faster and easier identification, the MultiLocking screws and all VERTICALE Pedicle Screws are color-coded by diameter. The length gradations are in 5-mm increments.

The screw portfolio includes solid as well as cannulated and cannulated/fenestrated MultiLocking short-head and long-head screws (reduction screws).



NOTE: After removing the locking screw, the tabs of the long-head screws can be broken off beforehand and then the long-head screws can be used as short-head screws. This process is described in the section on removing the tabs.

NOTE: Using the A-P X-ray image, choose pedicle screws according to the pedicle diameter with the largest possible diameter. The length of the screw should be such that it reaches at least 2/3 of the diameter of the vertebral body, and in the best case the anterior edge of the vertebral body. A sacral screw fixation should be barely bicortical (perforation of the ventral cortex with at most one thread).

INSTRUMENTATION WITH VERTICALE[®] MULTILOCKING SHORT-HEAD SCREWS

The MultiLocking short-head screws are suitable for both open surgery and the minimally invasive technique. For both techniques the same instrumentation described below can be used.

Screw attachment with the locking and reduction tower

VI-5440
VERTICALE ML Locking and
Reduction Tower



The MultiLocking short-head screw is attached with the help of the VERTICALE ML Locking and Reduction Tower. The VERTICALE ML Locking and Reduction Tower as well as the MultiLocking screw have a lengthwise laser marking that indicates the correct orientation. The VERTICALE ML Locking and Reduction Tower is attached to a MultiLocking screw by pressing the clip and guiding the attachment opening over the MultiLocking screw and engaging it with the hook groove (Fig. 1).



Fig. 1 Attachment of the MultiLocking short-head screw with the help of the VERTICALE ML Locking and Reduction Tower.

Temporary fixation of the polyaxiality

GI-3111
Ratchet T-Handle



VI-5440
VERTICALE ML Locking and
Reduction Tower



VI-5441
VERTICALE ML LRT Insert Quick
Release



VI-5442
VERTICALE ML LRT Insert,
adjustable



VI-5444
VERTICALE ML LRT Adapter



The MultiLocking short-head screws have an integrated locking mechanism that can be activated with the instrumentation. To temporarily fix the polyaxiality, the VERTICALE ML Locking and Reduction Tower must be connected to the MultiLocking short-head screw. If the VERTICALE ML LRT Insert Quick Release is in the VERTICALE ML Locking and Reduction Tower, the polyaxiality of the screw can be fixed and released again at any time by opening and closing the lever of the locking and reduction tower (Fig. 2).

- I. Align the instrument with the laser markings and insert the VERTICALE ML LRT Insert Quick Release into the VERTICALE ML Locking and Reduction Tower by pushing the “PRESS” button (Fig. 3).
- II. Then guide the rear lever into the notch on the VERTICALE ML Locking and Reduction Tower and engage it along the axial groove until it clicks into place.
- III. After closing the lever, the instrument is connected to the implant.

Alternatively, a VERTICALE ML LRT Insert, adjustable, can be used for the VERTICALE ML Locking and Reduction Tower (Fig. 4). To do so, the VERTICALE ML LRT Insert, adjustable, is inserted into the VERTICALE ML Locking and Reduction Tower. Align the instrument with the laser markings and insert the VERTICALE ML LRT Insert, adjustable, into the VERTICALE ML Locking and Reduction Tower by pushing the “PRESS” button. To temporarily fix the polyaxiality, the nut on the end of the VERTICALE ML LRT Insert, adjustable, is screwed in the clockwise direction. For better application of the torque, an attachable VERTICALE ML LRT Adapter can be used (Fig. 5).



Fig. 2 Temporary fixation of the polyaxiality with the VERTICALE ML Locking and Reduction Tower and the VERTICALE ML LRT Insert Quick Release; top) polyaxiality can move freely; below) polyaxiality locked as soon as the proximal lever is tilted.



Fig. 3 VERTICALE ML Locking and Reduction Tower with the VERTICALE ML LRT Insert Quick Release.



Fig. 4 VERTICALE ML Locking and Reduction Tower with the VERTICALE ML LRT Insert, adjustable.

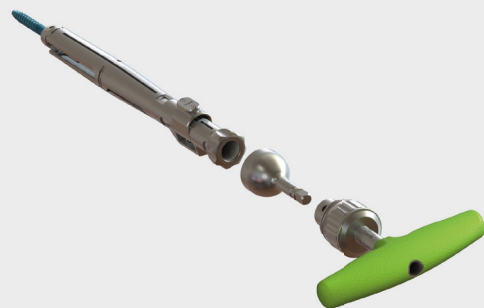

Fig. 5 Temporary fixation of the polyaxiality with the VERTICALE ML Locking and Reduction Tower, the VERTICALE ML LRT Insert, adjustable, and the VERTICALE ML LRT Adapter.

Preparing the pedicle screwdriver

GI-3111
Ratchet T-Handle



VI-4050
VERTICALE MIS Pedicle
Screwdriver



The VERTICALE Pedicle Screwdriver is used to screw in the VERTICALE MultiLocking Pedicle Screws.

To attach the MultiLocking pedicle screw, the VERTICALE MIS Pedicle Screwdriver, either through the VERTICALE ML LRT Insert Quick Release (Fig. 6) or the VERTICALE ML LRT Insert, adjustable (Fig. 7), depending on which is used in assembly with the VERTICALE ML Locking and Reduction Tower, is inserted into the inner Torx of the screw shaft and rotated over the outer sleeve of the pedicle screwdriver.



Fig. 6 VERTICALE ML Locking and Reduction Tower with the VERTICALE ML LRT Insert Quick Release and the MIS pedicle screwdriver.



Fig. 7 VERTICALE ML Locking and Reduction Tower with the VERTICALE ML LRT Insert, adjustable and the MIS pedicle screwdriver.

Pedicle screw placement

GI-3111
Ratchet T-Handle



VI-4050
VERTICALE MIS Pedicle
Driver



The MultiLocking pedicle screws are screwed into the prepared screw channel, monitored by an image intensifier, until the screw shaft is fully inserted into the pedicle. The pedicle screwdriver with the pedicle screw is disengaged from the mounted VERTICALE ML Locking and Reduction Tower by rotating the lower part of the handle counterclockwise. This process is repeated until all the MultiLocking pedicle screws have been placed with the respective VERTICALE ML Locking and Reduction Towers.

NOTE: for the minimally invasive approach, please ensure that the dilators are removed before inserting the screws. The dilators cannot be removed once the screws are inserted because of the design of the LRT instruments.

Selecting and inserting the rods

VI-5460
VERTICALE ML Rod Gauge



VI-4061
VERTICALE MIS Rod Length
Verifier



The required rod length is determined using the VERTICALE ML Rod Gauge.

- I.** The vertically variable measuring rod of the rod gauge is inserted fully into the superior VERTICALE ML Locking and Reduction Tower until the tip of the shaft is positioned in the screw head. The adjustment rail is positioned on top of the locking and reduction tower at this point. Now tighten the rotary knob.
- II.** The horizontally variable rod of the rod gauge is inserted fully into the inferior VERTICALE ML Locking and Reduction Tower and into the screw head. The adjustable unit is now fixed into position using the rotary knob (Fig. 8). The horizontally variable measuring rod must now be pulled back fully. If this step is not completed, the rod gauge becomes incorrectly adjusted on removal. The rod gauge can be removed from the locking and reduction towers, the movable measuring rod pushed downwards until the green marking is reached, and the appropriate rod read on the VERTICALE MIS Rod Length Verifier.

The rods are placed as described in the VERTICALE Open or MIS Standard Instrumentation Guide.

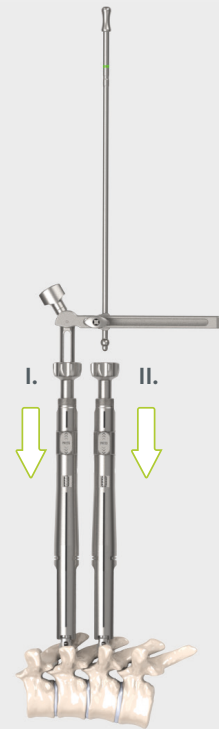

Fig. 8 Insertion of the VERTICALE ML Rod Gauge into the VERTICALE ML Locking and Reduction Towers and the VERTICALE ML LRT Insert, adjustable.

Temporary fixation of the set screw

VI-4120
VERTICALE MIS Set Screw
Starter



The set screw is inserted using the VERTICALE MIS Set Screw Starter. For this purpose, the MIS Starter Inner Shaft is inserted into the MIS Starter Basic Core and secured using the MIS Starter Turning Knob. Using the VERTICALE MIS Set Screw Starter, the set screw is attached and guided through the VERTICALE ML Locking and Reduction Tower. The set screw is temporarily fixed by gentle tightening (Fig. 9).



Fig. 9 Temporary fixation of the set screw with the VERTICALE MIS Set Screw Starter.

NOTE: Set screws should always be inserted with a smooth clockwise rotation. To prevent tilting, a brief prior counterclockwise rotation can facilitate insertion of the set screw into the first thread.

Reduction with the locking and reduction tower

GI-3111
Ratchet T-Handle



VI-5443
VERTICALE ML LRT Reduction
Insert



VI-5444
VERTICALE ML LRT Adapter



The VERTICALE ML LRT Reduction Insert is inserted into the VERTICALE ML Locking and Reduction Tower by pushing the “PRESS” button. Laser markings again help here with correct alignment (Fig. 10). By screwing in the reduction insert, the reduction maneuver is performed under control. If greater reduction forces are necessary, an attachable VERTICALE ML LRT Adapter can also be used (Fig. 11).

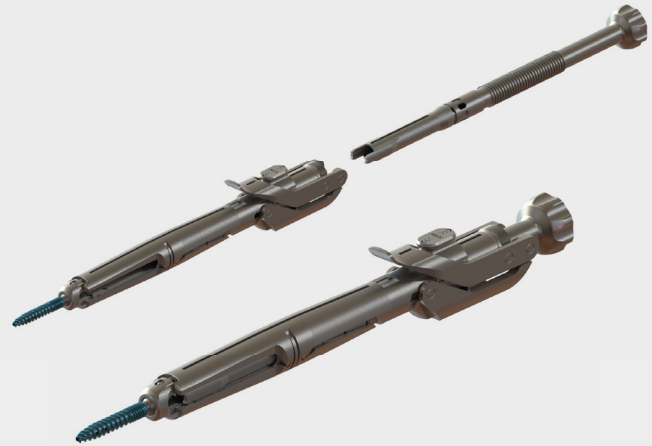

Fig. 10 Reduction maneuver with the VERTICALE ML LRT Reduction Insert.



Fig. 11 Reduction maneuver with the VERTICALE ML LRT Adapter and the ratchet T-handle for better tightening of the reduction insert.

Final tightening using the counter torque

VI-4160
VERTICALE MIS Counter Torque



VI-4170
VERTICALE MIS T25
Torque Limiter 10 Nm



For final tightening, the VERTICALE MIS T25 Torque Limiter and the MIS counter torque are used. The VERTICALE MIS T25 Torque Limiter is first guided through the VERTICALE ML Locking and Reduction Tower and the set screw is tightened in its final position with a torque of 10 Nm. It is important to use the VERTICALE MIS Counter Torque to stabilize the rotation when tightening the set screw (Fig. 12). An audible click indicates that the torque is reached.

After the final tightening, the temporary fixation of the polyaxiality must be released again using the nut if using the LRT Insert, adjustable, and the lever if using the LRT Insert, quick release.

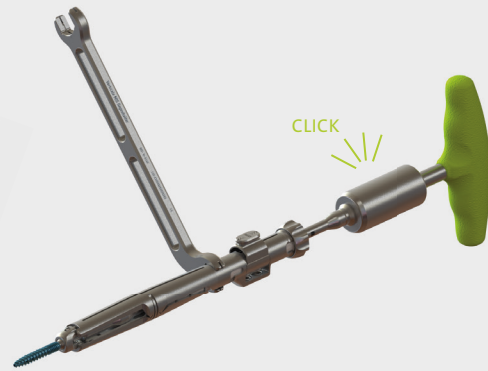

Fig. 12 Final tightening of the set screw with the VERTICALE ML Locking and Reduction Tower, the ML LRT Insert, adjustable, the VERTICALE MIS T25 Torque Limiter, and the VERTICALE MIS Counter Torque.

NOTE: After this process it is recommended to repeat the tightening of the set screw using the torque limiter and the counter torque.

Reconnecting the locking and reduction tower

VI-4190
VERTICALE MIS Tower Reconnecting Tool



VI-5440
VERTICALE ML Locking and Reduction Tower



VI-5441
VERTICALE ML LRT Insert Quick Release



VI-5442
VERTICALE ML LRT Insert, adjustable



The VERTICALE MIS Working Tower Reconnecting Tool can be used to reattach a previously removed VERTICALE ML Locking and Reduction Tower on a MultiLocking screw in situ by fixing and tightening the reconstructor onto the set screw. The VERTICALE ML Locking and Reduction Tower is guided over the working tower reconnecting tool until it can be placed on the MultiLocking screw. The inserts (VERTICALE ML LRT Insert Quick Release or VERTICALE ML LRT Insert, adjustable) can then be guided over the VERTICALE MIS Working Tower Reconnecting Tool. The MIS Working Tower Connector can now be removed and the VERTICALE ML Locking and Reduction Tower is ready for use on the MultiLocking screw (Fig. 13).

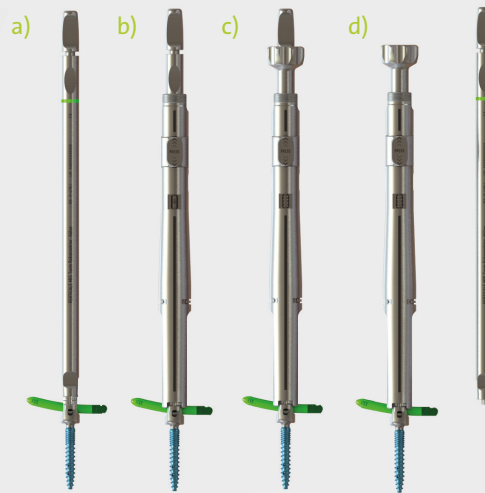
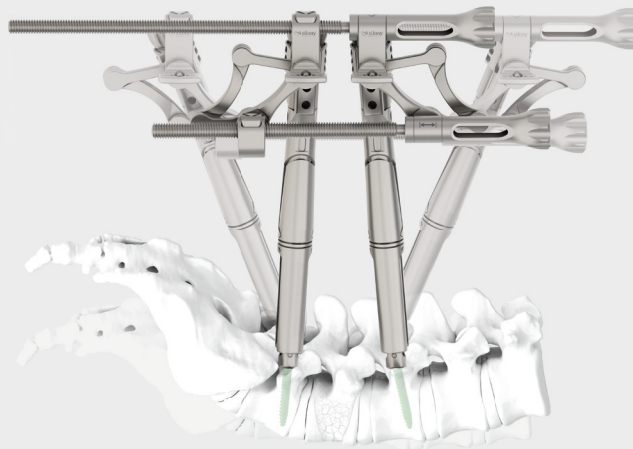

Fig. 13 Steps to reconnect the VERTICALE ML Locking and Reduction Tower; a) attach and fix the VERTICALE MIS Working Tower Reconnecting Tool; b) insert the VERTICALE ML Locking and Reduction Tower over the MIS working tower reconnecting tool up to the MultiLocking screw; c) insert the screw-mountable insert (or the quick release insert) over the MIS working tower reconnecting tool; d) remove the MIS Working Tower Reconnecting Tool.

Corrective maneuver with the fracture correction frame

With the help of the VERTICALE ML Fracture Correction Frame, a (parallel) distraction, compression, and lordosis or kyphosis can be performed. The assembly ensures that the distance between the pedicle screw heads is kept constant during the adjustment or correction of a lordosis angle. The VERTICALE ML Fracture Correction Frame can be connected on one side with the VERTICALE ML Locking and Reduction Towers and on the other with the VERTICALE MIS Working Towers.

In the following section we describe the instrumentation sequence when using the fracture correction frame with the VERTICALE ML Locking and Reduction Towers.



NOTE: When using the VERTICALE ML Locking and Reduction Towers, the VERTICALE ML LRT Inserts, adjustable must be used for temporary polyaxial fixation.

Preparing the fracture frame

VI-5450.1
ML FCF Basic Core



VI-5450.2
ML FCF Quick Release Unit



VI-5450.3
ML FCF Clamp (2x)

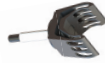

The VERTICALE ML Fracture Correction Frame can be disassembled to ensure improved cleaning. For the assembly, slide the ML FCF Quick Release Unit onto the spindles of the ML FCF Basic Core by activating the buttons for quick sliding. Alternatively, you can turn the spindles clockwise to attach them (Fig. 14).

Then attach both the ML FCF Clamps by inserting these into the particular threaded connection and rotating the clamp handles on the back clockwise while holding the clamps firmly (Fig. 15). Before using the VERTICALE ML Fracture Correction Frame, the clamps must be able to move freely.



Fig. 14 Assembly of the VERTICALE ML Fracture Correction Frame and attachment of the ML FCF Quick Release Unit (top) using the buttons; (below) by turning the spindles.



Fig. 15 Attachment of the VERTICALE ML FCF Clamps

Preparing the fracture frame

To fix the VERTICALE ML Fracture Correction Frame to the ML Locking and Reduction Towers, the VERTICALE ML FCF Clamps of the VERTICALE ML Fracture Correction Frame are clipped onto the cylindrical section on the top of the ML Locking and Reduction Towers. When doing so, ensure that the “PRESS” buttons of the ML Locking and Reduction Towers are facing the medial direction (Fig. 16).

Fixing the VERTICALE ML Fracture Correction Frame

- I.** Activate, if necessary, the temporary locking of the polyaxiality on the VERTICALE ML Locking and Reduction Towers
- II.** Press the top button to adjust the width of the VERTICALE ML FCF Clamps to the distance of the proximal ends of both towers
- III.** Clip the VERTICALE ML FCF Clamps one to each tower (do not fix the clamps yet)
- IV.** Press the bottom button and position the lower hinge points at the particular estimated position of the pedicle screw
- V.** Fix the VERTICALE ML FCF Clamps.



Fig. 16 Two MultiLocking pedicle screws with adapted VERTICALE ML Locking and Reduction Towers and an attached VERTICALE ML Fracture Correction Frame.

NOTE: Ensure that the lateral rod openings on the VERTICALE ML Locking and Reduction Towers have the same alignment before the VERTICALE ML FCF Clamps are fixed so that the rod can then be passed through.

Parallel distraction/compression

VI-5450
VERTICALE ML Fracture Correction Frame



VI-5440
VERTICALE ML Locking and Reduction Tower



VI-5442
VERTICALE ML LRT Insert, adjustable



VI-5444
VERTICALE ML LRT Adapter



Using the bottom adjustment screw or the bottom button, the pedicle screw distance can now be adjusted. For distraction with quicker adjustment, press the bottom button while advancing the FCF Quick Release Unit. For fine adjustment, rotate the bottom spindle on the adjustment screw counterclockwise.

To achieve compression, press the bottom button while advancing the FCF Quick Release Unit. Alternatively, rotate the bottom spindle on the adjustment screw clockwise (Fig. 17).

For better application of the torque, an attachable VERTICALE ML LRT Adapter can be used.

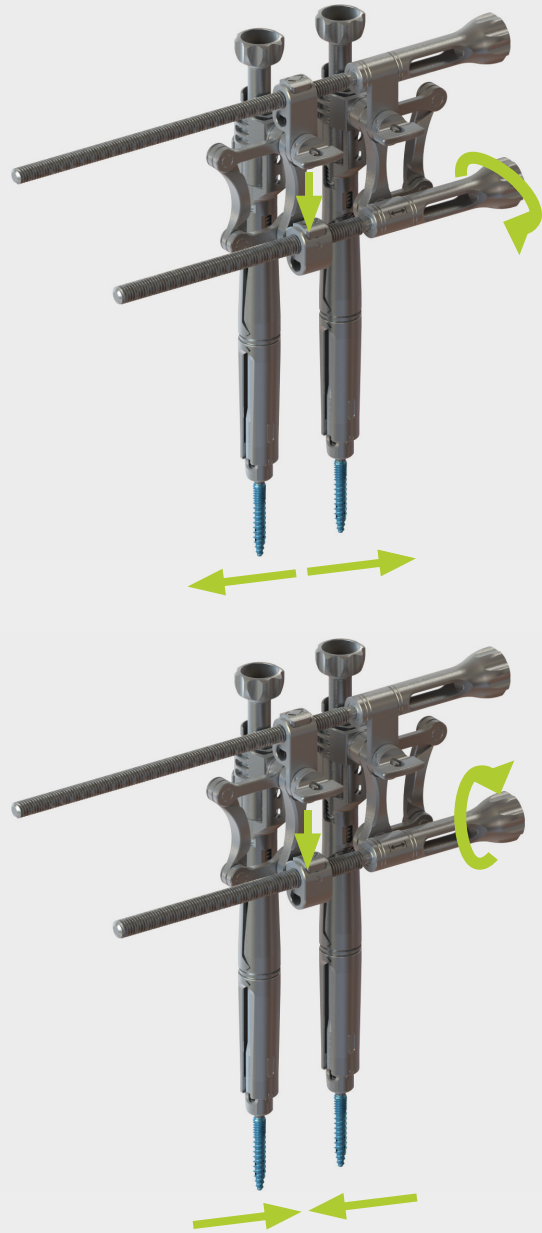

Fig. 17 top) Rotating the bottom adjustment screw counterclockwise or pushing the bottom button and pulling the quick release unit apart leads to distraction; bottom) rotating the bottom adjustment screw clockwise or pushing the bottom button and pushing the quick release unit together leads to compression.

NOTE: So that the rod can move freely in the screw head, the set screw must not be securely tightened in the working tower without a rod inserter during the compression and distraction maneuver. It is recommended that the correction maneuvers are performed using an image intensifier for lateral verification to ensure adequate manipulation of the spinal segment.

Lordosis/kyphosis

VI-5450
VERTICALE ML Fracture Correction Frame



VI-5440
VERTICALE ML Locking and Reduction Tower



VI-5442
VERTICALE ML LRT Insert, adjustable



VI-5444
VERTICALE ML LRT ADAPTER



With the top adjustment screw or top button, the angle of the towers can be adjusted (while keeping the pedicle screw heads in the same position). For lordosis with quicker adjustment, press the bottom button while pushing the FCF Quick Release Unit together. For fine adjustment, rotate the top spindle on the adjustment screw clockwise. To achieve kyphosis, press the top button while sliding the FCF Quick Release Unit away. Alternatively, rotate the top spindle on the adjustment screw clockwise (Fig. 18). For better application of the torque, an attachable VERTICALE ML LRT Adapter can be used.

NOTE: So that the rod can move freely in the screw head, the set screw must not be securely tightened in the working tower without a rod inserter during the lordosis and kyphosis maneuver. It is recommended that the correction maneuvers are performed using an image intensifier for lateral verification to ensure adequate manipulation of the spinal segment.

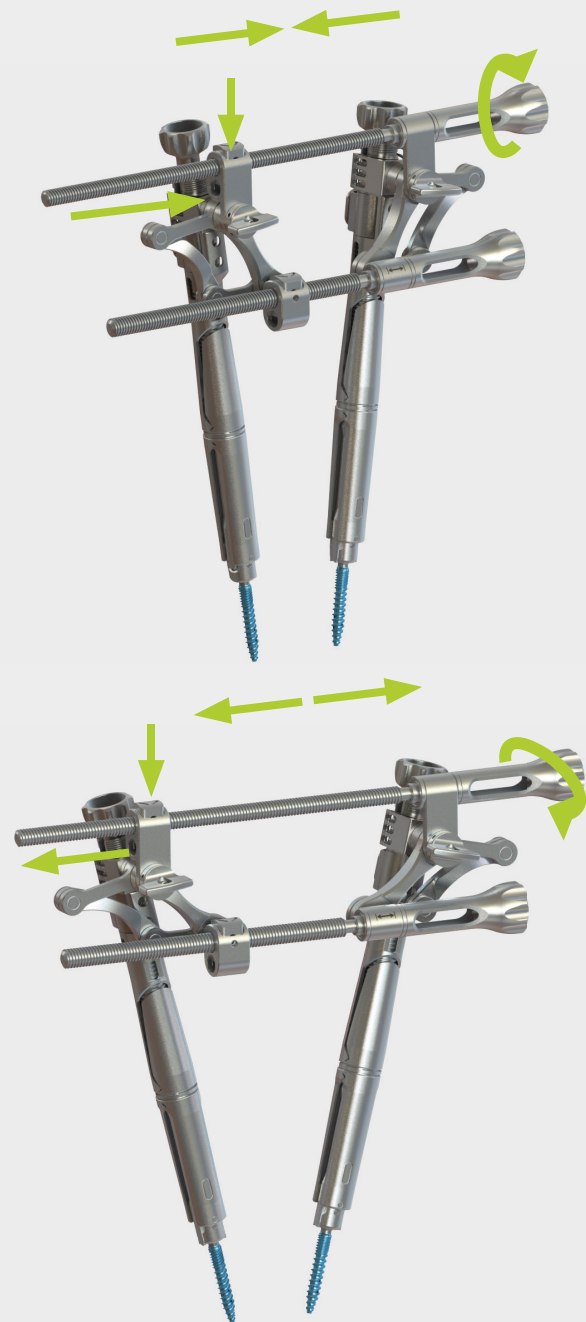

Fig. 18 top) Rotating the top adjustment screw clockwise or pushing the top button and pushing the quick release unit together leads to distraction; bottom) rotating the top adjustment screw counterclockwise or pushing the top button and separating the quick release unit leads to compression.

Removing the fracture frame

After the corrective maneuver, the set screws must be tightened. After this process, the spindles must no longer be activated. To remove the VERTICALE ML Fracture Correction Frame, carry out the following steps as described:

- I. Release the tension by activating the button on the VERTICALE ML FCF Quick Release Unit
- II. Open the VERTICALE ML FCF Clamps by a half turn. Do not release the clips too far to prevent excessive torque exerted on the threaded spindle during removal
- III. Grasp the middle of the VERTICALE ML FCF Basic Core using the VERTICALE ML FCF Quick Release Unit and swing it up out of the way. This releases the VERTICALE ML FCF Clamps from the VERTICALE ML Locking and Working Towers.

INSTRUMENTATION WITH VERTICALE[®] MULTILOCKING LONG-HEAD SCREWS

The MultiLocking long-head screws are only suitable for open surgery.

Inserting the screw

GI-3111
Ratchet T-Handle



VI-1130
VERTICALE Pedicle Screwdriver
T25



The VERTICALE Pedicle Screwdriver is used to screw in the multi-locking long-head screws. The preparation of the pedicle screwdriver and attachment of the screws is carried out as described in the VERTICALE OPEN Standard Instrumentation Guide.

Temporary fixation of the polyaxiality

VI-5010
VERTICALE ML Derotation
Sleeve



VI-5030
VERTICALE ML Locking Driver



VI-5040
VERTICALE ML Locking Limiter
0.9 Nm



VI-5035
VERTICALE ML Locking Driver
Clip-On



The MultiLocking long-head screws are supplied pre-mounted. They have a locking screw on the side. As soon as this locking screw is fixed, the polyaxiality is locked. Before the polyaxiality is fixed, the VERTICALE ML Derotation Sleeve is guided over the MultiLocking long-head screw. Orient the VERTICALE ML Derotation Sleeve so that the yellow marking of the VERTICALE ML Derotation Sleeve is aligned with the locking screw (Fig. 19). This ensures that the VERTICALE ML Locking Driver is aligned precisely with the locking screw for temporary fixation.

For temporary fixation, the VERTICALE ML Locking Limiter 0.9 Nm is connected to the VERTICALE ML Locking Driver with the help of an AO coupling. The VERTICALE ML Locking Driver can now be guided into the lateral channel of the VERTICALE ML Derotation Sleeve (Fig. 20). Using the VERTICALE ML Derotation Sleeve, the desired orientation of the MultiLocking screw can be set. As soon as the desired orientation is set, the polyaxiality can now be temporarily fixed by tightening the VERTICALE ML Locking Limiter until the torque limiter is released. This is indicated by an audible click. The polyaxiality can be restored by releasing the locking screw. Without the VERTICALE ML Derotation Sleeve the locking screw can alternatively be tightened or released using the VERTICALE ML Locking Driver Clip-On (Fig. 21).

NOTE: To avoid overloading when fixing the locking screw, a torque limiter with a maximum torque of 0.9 Nm must be used. Only the VERTICALE ML Locking Limiter 0.9 Nm may be used here.

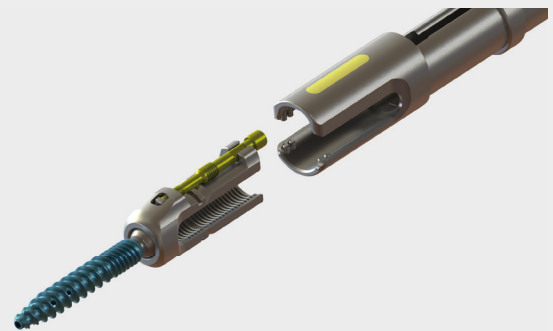

Fig. 19 Orientation and attachment of the VERTICALE ML Derotation Sleeve.

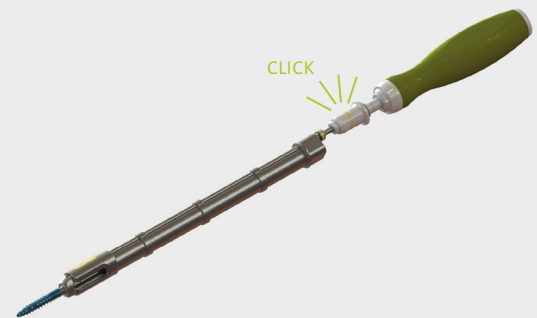

Fig. 20 Fixation of the locking screw to temporarily fix the polyaxiality with the help of the VERTICALE ML Derotation Sleeve, the VERTICALE ML Locking Driver, and the VERTICALE ML Locking Limiter.



Fig. 21 Fixation of the locking screw to temporarily fix the polyaxiality with the help of the VERTICALE ML Locking Driver Clip-On and the VERTICALE ML Locking Limiter.

Selecting and inserting the rods

The rods are selected and placed as described in the VERTICALE OPEN Standard Instrumentation Guide.

Temporary fixation of the set screw

VI-1420
VERTICALE Set Screw Starter



VI-5010
VERTICALE ML Derotation
Sleeve



VI-5041
VERTICALE ML Counter Torque



The set screw is inserted with the VERTICALE Set Screw Starter. Using the VERTICALE Set Screw Starter, the set screw is attached and guided through the VERTICALE ML Derotation Sleeve (Fig. 22). The VERTICALE ML Derotation Sleeve prevents inadvertent spreading of the tabs while the set screw is being inserted.

For greater rotation protection when tightening the set screw, the VERTICALE ML Counter Torque can alternatively be used as a guide for the set screw starter (Fig. 23).



Fig. 22 Temporary fixation of the set screw with the VERTICALE ML Derotation Sleeve as a guide.

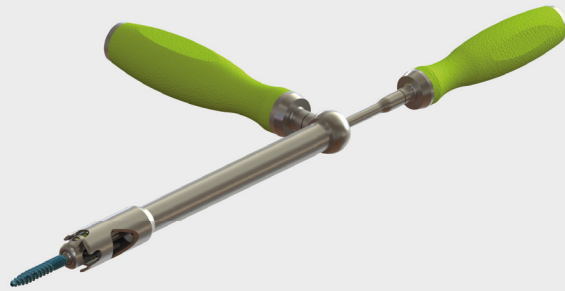

Fig. 23 Temporary fixation of the set screw with the VERTICALE ML Counter Torque as a guide.

Final tightening using the counter torque

VI-2440
VERTICALE T25 Torque Limiter
10 Nm



VI-5010
VERTICALE ML Derotation Sleeve



VI-5020
VERTICALE ML Adapter for Derotation Sleeve



VI-5041
VERTICALE ML Counter Torque



VI-5035
VERTICALE ML Locking Driver Clip-On



For final tightening of the set screw, the VERTICALE T25 Torque Limiter 10 Nm is used.

The VERTICALE ML Counter Torque is placed directly on the screw head. The VERTICALE T25 Torque Limiter can then be guided through the counter torque and the set screw tightened in its final position with a torque of 10 Nm. An audible click indicates that the torque is reached (Fig. 24).

Alternatively, the VERTICALE ML Derotation Sleeve combined with the VERTICALE ML Adapter for Derotation Sleeve can be used as a rotation stabilizer (Fig. 25).

After the final tightening, the temporary fixation of the polyaxiality must be released again by screwing the locking screw to a withdrawal position until the stop can be felt (Fig. 26). The VERTICALE ML Locking Driver Clip-On can be used to loosen the locking screw.

NOTE: After this process it is recommended to repeat the tightening of the set screw using the torque limiter and the counter torque.

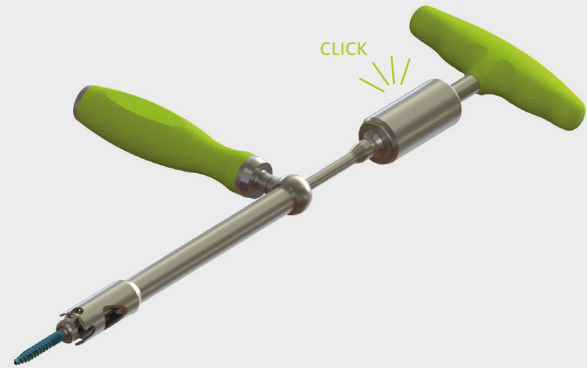

Fig. 24 Final tightening of the set screw with the VERTICALE ML Counter Torque and the VERTICALE T25 Torque Limiter.

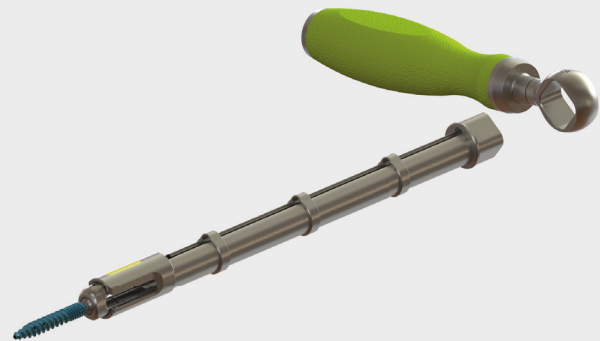

Fig. 25 Final screwing in with the VERTICALE ML Derotation Sleeve combined with the VERTICALE ML Adapter for Derotation Sleeve as a counter torque.



Fig. 26 Multilocking long-head screw. Top) with the locking screw in a position that can fix the polyaxiality; bottom) locking screw in the final end position up to the stop. The locking screw is now released from the bottom head section.

Removing the tabs

After the locking screw has been brought into its final position, the tabs can be broken off with a surgical clamp and removed.

VERTICALE® MULTILOCKING PRODUCT INFORMATION

VERTICALE ML Implants by article number	PI 02
VERTICALE Instruments by article number	PI 06
VERTICALE Alphabetic Index	PI 08

VERTICALE® MultiLocking Implants

System:
VERTICALE ML

Implant type:
Pedicle screw

Typing:
Polyaxial, solid shaft

Material:
Ti6Al4V ELI

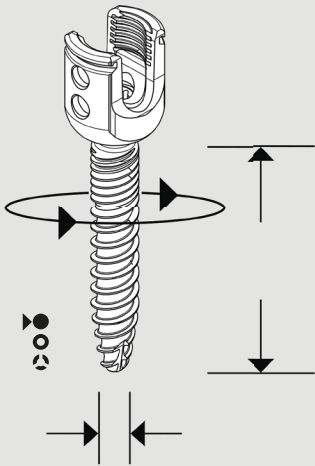

Article number	Description	Illustration	
S-VML-4525-S2	VERTICALE MultiLock screw 4.5 × 25 mm, solid		
S-VML-4530-S2	VERTICALE MultiLock screw 4.5 × 30 mm, solid		
S-VML-4535-S2	VERTICALE MultiLock screw 4.5 × 35 mm, solid		
S-VML-4540-S2	VERTICALE MultiLock screw 4.5 × 40 mm, solid		
S-VML-4545-S2	VERTICALE MultiLock screw 4.5 × 45 mm, solid		
S-VML-4550-S2	VERTICALE MultiLock screw 4.5 × 50 mm, solid		
S-VML-5225-S2	VERTICALE MultiLock screw 5.2 × 25 mm, solid		
S-VML-5230-S2	VERTICALE MultiLock screw 5.2 × 30 mm, solid		
S-VML-5235-S2	VERTICALE MultiLock screw 5.2 × 35 mm, solid		
S-VML-5240-S2	VERTICALE MultiLock screw 5.2 × 40 mm, solid		
S-VML-5245-S2	VERTICALE MultiLock screw 5.2 × 45 mm, solid		
S-VML-5250-S2	VERTICALE MultiLock screw 5.2 × 50 mm, solid		
S-VML-5255-S2	VERTICALE MultiLock screw 5.2 × 55 mm, solid		
S-VML-5260-S2	VERTICALE MultiLock screw 5.2 × 60 mm, solid		
S-VML-6225-S2	VERTICALE MultiLock screw 6.2 × 25 mm, solid		
S-VML-6230-S2	VERTICALE MultiLock screw 6.2 × 30 mm, solid		
S-VML-6235-S2	VERTICALE MultiLock screw 6.2 × 35 mm, solid		
S-VML-6240-S2	VERTICALE MultiLock screw 6.2 × 40 mm, solid		
S-VML-6245-S2	VERTICALE MultiLock screw 6.2 × 45 mm, solid		
S-VML-6250-S2	VERTICALE MultiLock screw 6.2 × 50 mm, solid		
S-VML-6255-S2	VERTICALE MultiLock screw 6.2 × 55 mm, solid		
S-VML-6260-S2	VERTICALE MultiLock screw 6.2 × 60 mm, solid		
S-VML-7225-S2	VERTICALE MultiLock screw 7.2 × 25 mm, solid		
S-VML-7230-S2	VERTICALE MultiLock screw 7.2 × 30 mm, solid		
S-VML-7235-S2	VERTICALE MultiLock screw 7.2 × 35 mm, solid		
S-VML-7240-S2	VERTICALE MultiLock screw 7.2 × 40 mm, solid		
S-VML-7245-S2	VERTICALE MultiLock screw 7.2 × 45 mm, solid		
S-VML-7250-S2	VERTICALE MultiLock screw 7.2 × 50 mm, solid		
S-VML-7255-S2	VERTICALE MultiLock screw 7.2 × 55 mm, solid		
S-VML-7260-S2	VERTICALE MultiLock screw 7.2 × 60 mm, solid		
S-VML-7270-S2	VERTICALE MultiLock screw 7.2 × 70 mm, solid		
S-VML-7280-S2	VERTICALE MultiLock screw 7.2 × 80 mm, solid		

VERTICALE® Implants

System:
VERTICALE ML

Implant type:
Pedicle screw

Typing:
Polyaxial, cannulated
and fenestrated shaft

Material:
Ti6Al4V ELI

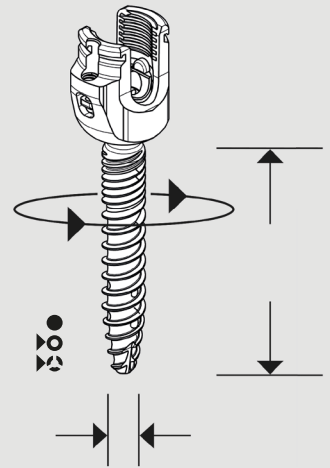

Article number	Description	Illustration
S-VML-4525-K2	VERTICALE MultiLock screw 4.5 × 25 mm, can	
S-VML-4530-K2	VERTICALE MultiLock screw 4.5 × 30 mm, can	
S-VML-4535-K2	VERTICALE MultiLock screw 4.5 × 35 mm, can	
S-VML-4540-K2	VERTICALE MultiLock screw 4.5 × 40 mm, can	
S-VML-4545-K2	VERTICALE MultiLock screw 4.5 × 45 mm, can	
S-VML-4550-K2	VERTICALE MultiLock screw 4.5 × 50 mm, can	
S-VML-5225-K2	VERTICALE MultiLock screw 5.2 × 25 mm, can	
S-VML-5230-K2	VERTICALE MultiLock screw 5.2 × 30 mm, can	
S-VML-5235-KF2	VERTICALE MultiLock screw 5.2 × 35 mm, can+fen	
S-VML-5240-KF2	VERTICALE MultiLock screw 5.2 × 40 mm, can+fen	
S-VML-5245-KF2	VERTICALE MultiLock screw 5.2 × 45 mm, can+fen	
S-VML-5250-KF2	VERTICALE MultiLock screw 5.2 × 50 mm, can+fen	
S-VML-5255-KF2	VERTICALE MultiLock screw 5.2 × 55 mm, can+fen	
S-VML-5260-KF2	VERTICALE MultiLock screw 5.2 × 60 mm, can+fen	
S-VML-6225-K2	VERTICALE MultiLock screw 6.2 × 25 mm, can	
S-VML-6230-K2	VERTICALE MultiLock screw 6.2 × 30 mm, can	
S-VML-6235-KF2	VERTICALE MultiLock screw 6.2 × 35 mm, can+fen	
S-VML-6240-KF2	VERTICALE MultiLock screw 6.2 × 40 mm, can+fen	
S-VML-6245-KF2	VERTICALE MultiLock screw 6.2 × 45 mm, can+fen	
S-VML-6250-KF2	VERTICALE MultiLock screw 6.2 × 50 mm, can+fen	
S-VML-6255-KF2	VERTICALE MultiLock screw 6.2 × 55 mm, can+fen	
S-VML-6260-KF2	VERTICALE MultiLock screw 6.2 × 60 mm, can+fen	
S-VML-7225-K2	VERTICALE MultiLock screw 7.2 × 25 mm, can	
S-VML-7230-K2	VERTICALE MultiLock screw 7.2 × 30 mm, can	
S-VML-7235-KF2	VERTICALE MultiLock screw 7.2 × 35 mm, can+fen	
S-VML-7240-KF2	VERTICALE MultiLock screw 7.2 × 40 mm, can+fen	
S-VML-7245-KF2	VERTICALE MultiLock screw 7.2 × 45 mm, can+fen	
S-VML-7250-KF2	VERTICALE MultiLock screw 7.2 × 50 mm, can+fen	
S-VML-7255-KF2	VERTICALE MultiLock screw 7.2 × 55 mm, can+fen	
S-VML-7260-KF2	VERTICALE MultiLock screw 7.2 × 60 mm, can+fen	
S-VML-7270-KF2	VERTICALE MultiLock screw 7.2 × 70 mm, can+fen	
S-VML-7280-KF2	VERTICALE MultiLock screw 7.2 × 80 mm, can+fen	

VERTICALE® Implants

System:
VERTICALE ML

Implant type:
Pedicle screw

Typing:
Polyaxial, reduction,
solid shaft

Material:
Ti6Al4V ELI

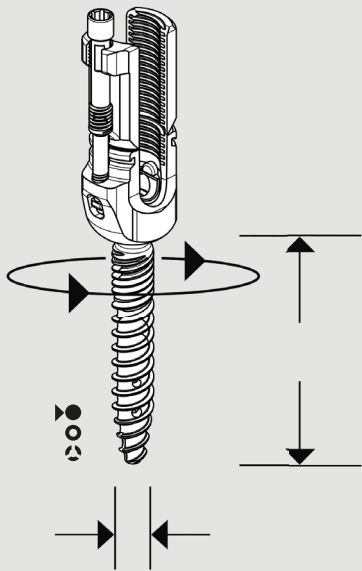

Article number	Description	Illustration
S-VML-4525-RS2	VERTICALE MultiLock Red 4.5 × 25 mm, solid	
S-VML-4530-RS2	VERTICALE MultiLock Red 4.5 × 30 mm, solid	
S-VML-4535-RS2	VERTICALE MultiLock Red 4.5 × 35 mm, solid	
S-VML-4540-RS2	VERTICALE MultiLock Red 4.5 × 40 mm, solid	
S-VML-4545-RS2	VERTICALE MultiLock Red 4.5 × 45 mm, solid	
S-VML-4550-RS2	VERTICALE MultiLock Red 4.5 × 50 mm, solid	
S-VML-5225-RS2	VERTICALE MultiLock Red 5.2 × 25 mm, solid	
S-VML-5230-RS2	VERTICALE MultiLock Red 5.2 × 30 mm, solid	
S-VML-5235-RS2	VERTICALE MultiLock Red 5.2 × 35 mm, solid	
S-VML-5240-RS2	VERTICALE MultiLock Red 5.2 × 40 mm, solid	
S-VML-5245-RS2	VERTICALE MultiLock Red 5.2 × 45 mm, solid	
S-VML-5250-RS2	VERTICALE MultiLock Red 5.2 × 50 mm, solid	
S-VML-5255-RS2	VERTICALE MultiLock Red 5.2 × 55 mm, solid	
S-VML-5260-RS2	VERTICALE MultiLock Red 5.2 × 60 mm, solid	
S-VML-6225-RS2	VERTICALE MultiLock Red 6.2 × 25 mm, solid	
S-VML-6230-RS2	VERTICALE MultiLock Red 6.2 × 30 mm, solid	
S-VML-6235-RS2	VERTICALE MultiLock Red 6.2 × 35 mm, solid	
S-VML-6240-RS2	VERTICALE MultiLock Red 6.2 × 40 mm, solid	
S-VML-6245-RS2	VERTICALE MultiLock Red 6.2 × 45 mm, solid	
S-VML-6250-RS2	VERTICALE MultiLock Red 6.2 × 50 mm, solid	
S-VML-6255-RS2	VERTICALE MultiLock Red 6.2 × 55 mm, solid	
S-VML-6260-RS2	VERTICALE MultiLock Red 6.2 × 60 mm, solid	
S-VML-7225-RS2	VERTICALE MultiLock Red 7.2 × 25 mm, solid	
S-VML-7230-RS2	VERTICALE MultiLock Red 7.2 × 30 mm, solid	
S-VML-7235-RS2	VERTICALE MultiLock Red 7.2 × 35 mm, solid	
S-VML-7240-RS2	VERTICALE MultiLock Red 7.2 × 40 mm, solid	
S-VML-7245-RS2	VERTICALE MultiLock Red 7.2 × 45 mm, solid	
S-VML-7250-RS2	VERTICALE MultiLock Red 7.2 × 50 mm, solid	
S-VML-7255-RS2	VERTICALE MultiLock Red 7.2 × 55 mm, solid	
S-VML-7260-RS2	VERTICALE MultiLock Red 7.2 × 60 mm, solid	
S-VML-7270-RS2	VERTICALE MultiLock Red 7.2 × 70 mm, solid	
S-VML-7280-RS2	VERTICALE MultiLock Red 7.2 × 80 mm, solid	

VERTICALE® Implants

System:
VERTICALE ML

Implant type:
Pedicle screw

Typing:
Polyaxial, reduction,
cannulated, and fe-
nestrated shaft

Material:
Ti6Al4V ELI

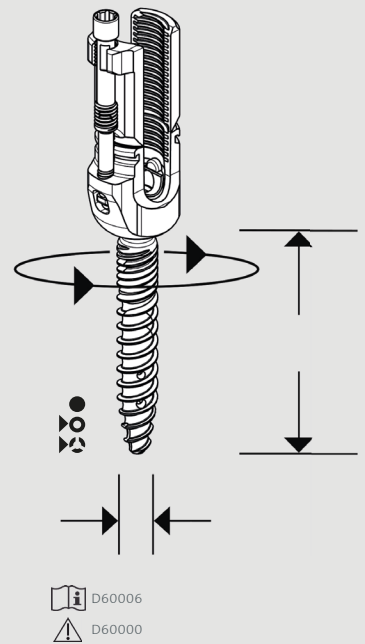

Article number	Description	Illustration	
S-VML-4525-RK2	VERTICALE MultiLock Red 4.5 × 25 mm, can		
S-VML-4530-RK2	VERTICALE MultiLock Red 4.5 × 30 mm, can		
S-VML-4535-RK2	VERTICALE MultiLock Red 4.5 × 35 mm, can		
S-VML-4540-RK2	VERTICALE MultiLock Red 4.5 × 40 mm, can		
S-VML-4545-RK2	VERTICALE MultiLock Red 4.5 × 45 mm, can		
S-VML-4550-RK2	VERTICALE MultiLock Red 4.5 × 50 mm, can		
S-VML-5225-RK2	VERTICALE MultiLock Red 5.2 × 25 mm, can		
S-VML-5230-RK2	VERTICALE MultiLock Red 5.2 × 30 mm, can		
S-VML-5235-RF2	VERTICALE MultiLock Red 5.2 × 35 mm, can+fen		
S-VML-5240-RF2	VERTICALE MultiLock Red 5.2 × 40 mm, can+fen		
S-VML-5245-RF2	VERTICALE MultiLock Red 5.2 × 45 mm, can+fen		
S-VML-5250-RF2	VERTICALE MultiLock Red 5.2 × 50 mm, can+fen		
S-VML-5255-RF2	VERTICALE MultiLock Red 5.2 × 55 mm, can+fen		
S-VML-5260-RF2	VERTICALE MultiLock Red 5.2 × 60 mm, can+fen		
S-VML-6225-RK2	VERTICALE MultiLock Red 6.2 × 25 mm, can		
S-VML-6230-RK2	VERTICALE MultiLock Red 6.2 × 30 mm, can		
S-VML-6235-RF2	VERTICALE MultiLock Red 6.2 × 35 mm, can+fen		
S-VML-6240-RF2	VERTICALE MultiLock Red 6.2 × 40 mm, can+fen		
S-VML-6245-RF2	VERTICALE MultiLock Red 6.2 × 45 mm, can+fen		
S-VML-6250-RF2	VERTICALE MultiLock Red 6.2 × 50 mm, can+fen		
S-VML-6255-RF2	VERTICALE MultiLock Red 6.2 × 55 mm, can+fen		
S-VML-6260-RF2	VERTICALE MultiLock Red 6.2 × 60 mm, can+fen		
S-VML-7225-RK2	VERTICALE MultiLock Red 7.2 × 25 mm, can		
S-VML-7230-RK2	VERTICALE MultiLock Red 7.2 × 30 mm, can		
S-VML-7235-RF2	VERTICALE MultiLock Red 7.2 × 35 mm, can+fen		
S-VML-7240-RF2	VERTICALE MultiLock Red 7.2 × 40 mm, can+fen		
S-VML-7245-RF2	VERTICALE MultiLock Red 7.2 × 45 mm, can+fen		
S-VML-7250-RF2	VERTICALE MultiLock Red 7.2 × 50 mm, can+fen		
S-VML-7255-RF2	VERTICALE MultiLock Red 7.2 × 55 mm, can+fen		
S-VML-7260-RF2	VERTICALE MultiLock Red 7.2 × 60 mm, can+fen		
S-VML-7270-RF2	VERTICALE MultiLock Red 7.2 × 70 mm, can+fen		
S-VML-7280-RF2	VERTICALE MultiLock Red 7.2 × 80 mm, can+fen		

VMS-2025	VERTICALE Set Screw Torx 25	
----------	-----------------------------	--

VERTICALE® ML Instruments (supplement to VERTICALE® Instruments)

Article number	Description	Illustration	Page
GI-3111	Ratchet T-Handle		9, 10, 13, 23
VI-1130	VERTICALE Pedicle Screwdriver T25		23
VI-1420	VERTICALE Set Screw Starter		25
VI-2440	VERTICALE T25 Torque Limiter 10 Nm		26
VI-4050	VERTICALE MIS Pedicle Screw Driver		10, 14
VI-4061	VERTICALE MIS Rod Length Verifier		11
VI-4120	VERTICALE MIS Set Screw Starter		12
VI-4160	VERTICALE MIS Counter Torque		14
VI-4170	VERTICALE MIS T25 Torque Limiter 10 Nm		14
VI-4190	VERTICALE MIS Tower Reconnecting Tool		15
VI-5010	VERTICALE ML Derotation Sleeve		24, 25, 26
VI-5020	VERTICALE ML Adapter for Derotation Sleeve		26
VI-5030	VERTICALE ML Locking Driver		24
VI-5035	VERTICALE ML Locking Driver Clip-On		24, 26
VI-5040	VERTICALE ML Locking Limiter 0.9 Nm		24
VI-5041	VERTICALE ML Counter Torque		9, 15

VERTICALE® ML Instruments (supplement to VERTICALE® Instruments)

Article number	Description	Illustration	Page
VI-5440	VERTICALE ML Locking and Reduction Tower		8, 9, 15, 19, 20
VI-5441	VERTICALE ML LRT Insert Quick Release		9, 15
VI-5442	VERTICALE ML LRT Insert, adjustable		9, 15, 19, 20
VI-5443	VERTICALE ML LRT Reduction Insert		13
VI-5444	VERTICALE ML LRT Adapter		9, 13, 19, 20
VI-5450	VERTICALE ML Fracture Correction Frame		17, 19, 20
VI-5460	VERTICALE ML Rod Gauge		11

VERTICALE® Alphabetical Index

A-Z	Description	Article number	Page
A	VERTICALE ML Adapter for Derotation Sleeve	VI-5020	26, PI 06
G	VERTICALE ML Counter Torque	VI-5041	25,26, PI 06
	VERTICALE MIS Counter Torque	VI-4160	14, PI 06
D	VERTICALE ML Derotation Sleeve	VI-5010	24, 25, 26, PI 06
F	VERTICALE ML Fracture Correction Frame	VI-5450	17, 19, 20, PI 07
L	VERTICALE ML LRT Insert Quick Release	VI-5441	9, 15, PI 07
	VERTICALE ML LRT Insert, adjustable	VI-5442	9, 15, 19, 20, PI 07
	VERTICALE ML LRT Reduction Insert	VI-5443	13, PI 07
	VERTICALE ML LRT Adapter	VI-5444	9, 13, 19, 20, PI 07
	VERTICALE ML Locking Driver	VI-5030	24, PI 06
	VERTICALE ML Locking Driver Clip-On	VI-5035	24, 26, PI 06
	VERTICALE ML Locking Limiter 0.9 Nm	VI-5040	24, PI 06
	VERTICALE ML Locking and Reduction Tower	VI-5440	8, 9, 15, 19, 20 PI 07
P	VERTICALE MIS Pedicle Screw Driver	VI-4050	10, 14, PI 06
	VERTICALE Pedicle Screwdriver T25	VI-1130	23, PI 06
R	VERTICALE MIS Rod Length Verifier	VI-4061	11, PI 06
	VERTICALE MIS Rod Gauge	VI-5460	11, PI 07
S	VERTICALE Set Screw Starter	VI-1420	25, PI 06
	VERTICALE MIS Set Screw Starter	VI-4120	12, PI 06
T	VERTICALE T25 Torque Limiter 10 Nm	VI-2440	26, PI 06
	VERTICALE MIS T25 Torque Limiter 10 Nm	VI-4170	14, PI 06
	Ratchet T-Handle	GI-3111	9, 10, 13, 23, PI 06
	VERTICALE MIS Tower Reconnecting Tool	VI-4190	15, PI 06



www.silony-medical.com

 **Silony Medical Corp.**
8200 NW 27th Street, Suite 104
Doral, FL 33122, USA
Phone +1 305 916 0016

 **Silony Medical GmbH**
Leinfelder Strasse 60
70771 Leinfelden-Echterdingen, Germany
Tel +49-711-782525-0
Fax +49-711-782525-11

This information is only intended for the USA and its territories.

D60065.a.EN 23.11.2020

